

## GSV-15KL4

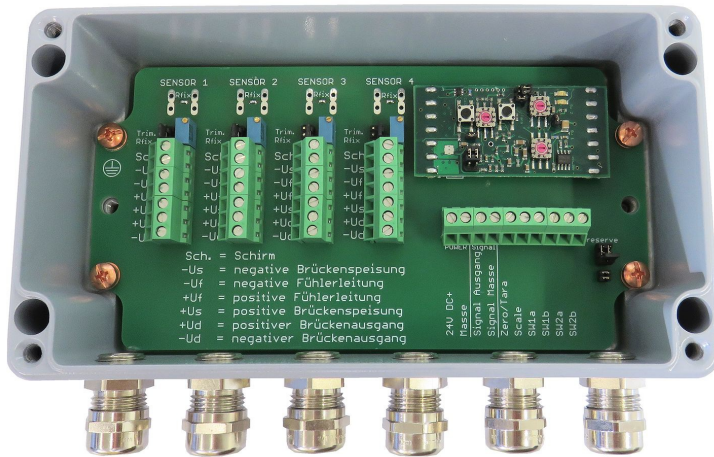

### Highlights

- Junction box for connecting up to four load cells
- Protection class IP66
- Output signal -10V...+10V or 4...20mA configurable
- Zero setting input via digital input
- Autoscale function for automatic adjustment of the input sensitivity
- Two threshold value switches, potential-free

## Description

The junction box with integrated measuring amplifier GSV-15KL4 is suitable for connection with sensors with strain gauges, such as force sensors, torque sensors, strain sensors and load cells.

The area of application is silo weighing with load cells or strain transducers.

Four terminal strips "RM5" are available for parallel connection of up to four load cells or four strain transducers within a piece of weighing equipment.

The junction box with dimensions of 220mm x 120mm x 81mm is designed with protection class IP66.

The integrated "GSV-15HSW"-type electronic measuring system has two threshold value outputs that can be set in 10% levels via coding switches.

An automatic zero adjustment can be triggered via a digital input or via a push switch. The zero point is stored in a non-volatile memory.

With the "scale function", any input size in a range between 0.2 mV/V and 3.5 mV/V can be scaled to an analogue output voltage of 10V or 20mA. The scale function is triggered via a push switch or via the digital input "scale". A coding switch enables you to set whether scale is to be carried out at full load or part load: For the scale function, input signals from 10% to 100% can be selected in 10% levels.

The integrated digital filter facilitates the formation of a stable, low-noise and zero point stable output signal especially at low frequencies from 5...105 Hz, and also at high amplifications of low input signals of 0.2 mV/V for example.

The resolution at the analogue output is 4,096 parts.

The sampling frequency can also be set to 1,000 Hz in the factory.

The analogue output can be configured as current or voltage output by means of jumpers.

## Technical Data

### Basis Data

Connection	screw terminal
Number of channels	1-Kanal

### Input analog

Input sensitivity-stepsless f	0.2 ... 3.5	mV/V
Input resistance strain-gauge-full-/half-bridge	70 ... 50000	Ohm

### Precision

Accuracy class	0,1%	
Temperature effect on the zero point	0.05	%FS/10°C
Temperature effect on the measuring sensitivity	0.01	%RD/10°C
Resolution	16	Bit

### Supply

Supply voltage f	11 ... 28	V
Strain gauge bridge supply	5	V

### Temperature

Rated temperature range f	-10 ... 85	°C
Operating temperature range f	-40 ... 85	°C
Environmental protection	IP66	

### Output analog

Number of analog outputs	1	
Voltage output f	-10 ... 10	V
Output resistance - voltage	33	Ohm
Current output f	4 ... 20	mA
Output resistance - current	300	Ohm

## Mounting

### Terminal assignment

#### 4x sensor connection, 7-pin terminal strip

Identification	Abbreviation	Designation	Alternative designations in the load cell data sheet
Sh.	GND	Ground, shield	shield, ground
E -	- U <sub>S</sub>	Negative bridge power supply	- excitation, - input, E-
S -	- U <sub>F</sub>	Negative sensor cable	- sense, S-
S +	+ U <sub>F</sub>	Positive sensor cable	+ sense, S+
E +	+ U <sub>S</sub>	Positive bridge power supply	+ excitation, + input, E+
O +	+ U <sub>D</sub>	Positive sensor output	+output
O -	- U <sub>D</sub>	Negative sensor output	- output

The terminals for the sensor cables remain unused if the load cells do not have six-conductor technology. The four terminal strips are connected in parallel. A maximum of four load cells with a terminal resistance of at least 350 ohm can be connected.

#### Connections for corner adjustment

Corner adjustment can be carried out with the help of trimmers or with permanent resistors if necessary. Corner adjustment requires specialised knowledge of scale construction.

The corner adjustment function is deactivated by default: The jumper position is Rf AND the soldered joint between the solder pins is closed.

Jumper position	Function
Rf.	In this position, an adjustable resistor is connected in series to the bridge power supply. The adjustable resistor can be soldered to the solder pins if necessary. A solder bridge is situated between the solder pins. When the soldered joint is closed, the resistance of the adjustable resistor is 0 ohm. The solder bridge must be opened so the bridge power supply can be reduced via the adjustable resistor.  Without the solder bridge and the adjustable resistor, the load cell does not supply the corresponding terminal strip with supply voltage.
Trim.	In this position, a trimmer is connected in series to the bridge power supply. The trimmer is arranged directly via the terminal strip.

### 1x 10-pin terminal strip

Terminal	Designation	Abbreviation	Description
1	24V DC	+U <sub>B</sub>	Supply voltage 11V...28V DC
2	Ground	GND <sub>B</sub>	Ground supply voltage
3	Signal out	U <sub>A</sub>	Analogue output -10V...+10V or 4mA...20mA
4	Signal ground	GND <sub>A</sub>	Ground analogue output
5	Zero setting	Zero	Digital input 11V...28V DC "zero"
6	Scale setting	Scale	Digital input 11V...28V "scale"
7	SP1a	SW1a	Switching output 1a
8	SP1b	SW1b	Switching output 1b
9	SP2a	SW2a	Switching output 2a
10	SP2b	SW2b	Switching output 2b

### Arrangement of buttons and selector switches

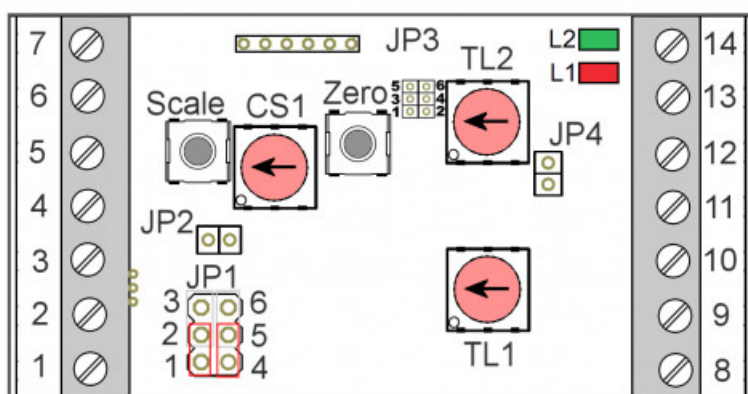

### Function of the buttons and selector switches

JP1	Closing of 1-2 and 4-5: Current output 2-3 and 5-6: Voltage output	
JP2	Opening: blocking the "scale" function at the button on the circuit board	

JP3	Opening of 1-2: blocking the "zero" function at the button on the circuit board Closing of 3-4: threshold values are inverted Closing of 5-6: default (producing factory settings)
JP4	Opening: switching on the maximum value mode
Scale	Operation (>2s) triggers "scale" function
Zero	Operation (>1s) triggers "zero" function
CS1	Selector switch to select the percentage of the measuring range at which the "scale" function is carried out. Setting in 10% steps from 10% to 100%.
TL1	Selector switch for switching output 1 for selecting the threshold value in percentage of the measuring range. Setting in 10% steps from 10% to 100%
TL2	Selector switch for switching output 2 for selecting the threshold value in percentage of the measuring range. Setting in 10% steps from 10% to 100%

## Light diodes

L2	green, continuous light: green: flashing:	Operational readiness indicator; Switching output 2 active, threshold value 2 exceeded
L1	red: flashing red continuous light	Switching output 1 active, threshold value 1 exceeded Error indicator: <ul style="list-style-type: none"> <li>• scale function was triggered without load or with negative load, or</li> <li>• measuring range was exceeded, or</li> <li>• scale or zero input is active;</li> </ul>

### Notes:

- The position of the selector switch is only adopted when the supply voltage is switched on. After a change, it has to be switched off and on.
- The jumpers JP2 and JP3 must be activated, otherwise the scale function and zero function are blocked.
- The position "0" of the selector switches CS1, TL1 and TL2 corresponds to 100%. The positions "1" to "9" correspond to 10% to 90%.
- In the delivery condition, the set input sensitivity is 2 mV/V and tare 0 mV/V; this corresponds to the factory settings.

## Operating the GSV-15HSW

The measuring amplifier GSV-15HSW optionally supplies an analogue output signal from -10.0V to 10.0V or 4mA...20mA. The default input sensitivity is 2 mV/V.

The input sensitivity (the measuring range) can be adjusted using the "scale function".

### Zero setting function (zero)

The output signal is automatically adjusted to 0.0V by applying a control pulse at the "zero" input. The control pulse must be at least 1s high and then 100

ms low. Tare functions within the range from 0.0 mV/V to 3.5 mV/V.

### Scale function (scale)

The measuring amplifier has a scale function. A high level at the "scale input" scales the current measuring signal to 10.0V or 20mA, or to the percentage of the output signal selected with the selector switch "CS1". The sensor must be tared in an unloaded state before the scale function is triggered. The sensor is then mechanically stressed. The output signal is automatically scaled by applying a control pulse at the "scale" input or by operating the "scale" button. The control pulse must be at least 2s high and then 100 ms low. Scaling of the measuring amplifier only functions in the positive measuring range.

### Configuring the scale function

The end value can also be scaled with less than 100% of the measuring range.

The calibration load proportion of the measuring range can be set with the selector switch "CS1" in 10% steps.

### Threshold value

The threshold value switch reacts when the threshold value is exceeded.

The potential-free switching outputs "a" and "b" are electrically connected when the threshold value is exceeded. They are opened accordingly when a jumper JP3 pin 3 and 4 is plugged in.

The standard threshold value is 90% of the measuring range. The threshold value output is switched to ground when 90% of the measuring range is exceeded. If the strain falls below 89%, the output switches to high-impedance.

### Configuring the threshold value function

The thresholds of the threshold value switches 1 and 2 can each be set in 10% steps with the selector switches TL1 and TL2.

### Corner adjustment

The terminal box allows the damping of the sensors 1 to 4, each individual series resistors. The resistor is effective by opening the solder bridge Rf in the cable + Us. It can be selected via pin header bar whether the trimmer or a fixed resistor is used.

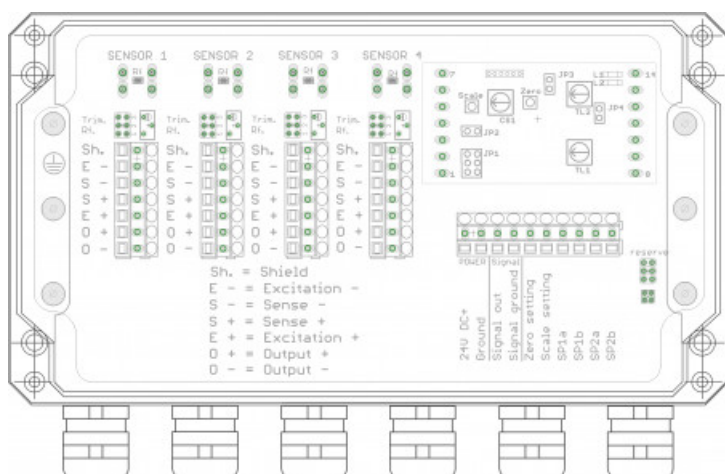

Position of the bridge for the use of spindle trimmer (1 kOhm)	Position of the bridge for the use of a fix resistor between left and right , two pole pin strip.

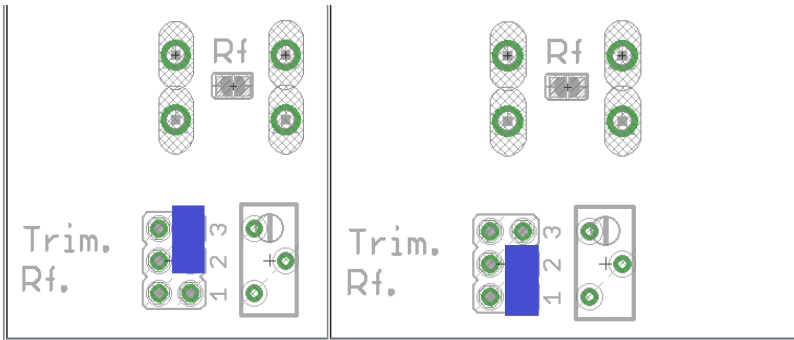



## accessories

Description	Description
	Mounting-FeET-300
	Mounting plates for GSV-4GPRS and GSV-4GPRSx2, GSV-8AS, also KL4 and GSV-15KL4;