



6-Channel measuring amplifier GSV-6BT

Operation manual

date:	28/06/2019
edition	ba-gsv6bt-v1.4-en
editor	Holger Kabelitz
changes	Changelog Seite 12



Measuring amplifier GSV-6BT

Contents

Measuring amplifier GSV-6BT.....	4
Description.....	4
More functions.....	5
Software / Communication.....	6
Current consumption.....	8
Sensor connection.....	8
Pin assignment.....	9
Strain gauge full bridges.....	9
SG half bridges.....	10
SG quarter bridge.....	10
voltage input UE 0-10V.....	10
Input for incremental encoder.....	11
Battery and maintenance charging.....	11
Auxiliary voltage supply for active sensors.....	11
Digital inputs and outputs.....	11
Function of the LEDs.....	12
Changelog.....	13

Measuring amplifier GSV-6BT

6-channel measuring amplifier
 Operation via Li-Ion battery 3.6V ... 4.2V
 Integrated battery charging circuit with 5V supply voltage
 Inputs configurable for full, half, quarter bridges, 350-1000 ohms, 0 ... 10V
 1x Bluetooth 4.0 (LE) (GATT) or Bluetooth Classic (SPP) configurable,
 Data logger function with SDCard up to 7x 2000 measured values/s
 Real Time Clock
 Send measured value: 6x 1 measured values/s ... 500 measured values/s
 Simultaneous scanning of channels 1 to 3 and 2 to 6
 Resolution <math><100\text{ nV / V}</math>
 Independent calculation of the 3 forces and torques for 6-axis sensors
 Reading TEDS data on channel 1
 counter / frequency / speed measurement on channel 7
 Two operating hours counters, one absolute and one recoverable



Description

The GSV-6BT is a 6-channel measuring amplifier with Bluetooth interface and data logger function. The dimensions are only 50mm x 20mm x 17mm.

The GSV-6BT has 6 measuring channels, of which the first channel is for full-bridge strain gauges, while channels 2 to 6 can be individually configured as voltage input (single-ended) or as strain gauge bridge input including half and quarter-bridge configuration.

Another seventh channel for acquiring digital pulses is available for connecting incremental encoders or as an input for square wave signals.

The number of channels in the data transmission is configurable from 1 to 7 channels. Channel 7 is reserved for the connection of incremental encoders, channel 1 is exclusively for the connection of DMS full-half or quarter-bridges.

Channel 1 supports the reading of TEDS memories to automatically configure the scaling factor for the connected sensor. In addition, two threshold outputs can be configured for channel 1.

The GSV-6BT has gold-plated solder pads for connecting the sensors and the supply voltage. For connection, strands with a cross-section of up to 0.09mm² (AWG28) are



suitable.

The Bluetooth connection supports BT Classic with Serial Port Profile (SPP) for complete configuration and continuous messaging, and BT LowEnergy (LE) with some services (GATT) for reading measurement data and battery voltage, e.g. via smartphone.

The measurement data can be recorded on a micro SD memory card, whereby there are various configuration options, such as continuous recording up to 3000 readings per second, long recording intervals with power management (battery saving mode) and digital input triggered recording. The recorded files can also be downloaded via Bluetooth SPP. A real-time clock creates timestamps in real time in the measurement data files.

More functions

- the connected 3.7V lithium-ion battery can be charged by an integrated charging circuit.
- the temperature in the device and the battery voltage can be measured
- The simultaneous zeroing of all channels can be triggered via a digital input („tare“).
- The GSV-6BT is protected against vibration by a full encapsulation in a plastic housing.
- The configuration and acquisition of measurement data is possible with the program GSVmulti in the mode "BT Classic" with Serial Port Profile (SPP)
- The integrated Bluetooth module has its own microcontroller, which offers the self-programming user a simple scripting language to implement their own embedded applications. All functions of the GSV-6 CPU and all supported BT services as well as additional digital outputs and a dedicated LED are available.
The factory-installed "BGscript" script serves the BT-LE requests and some SPP commands needed to perform the functionality described here. Communication with the GSV-6CPU is forwarded transparently.
- Using the microcontroller in the Bluetooth module and its BGscript amongst other things the BT device name, the BT transmission power and various battery saving modes are set, and the battery voltage is also displayed.

Software / Communication

Firstly, the GSV-6BT has to be searched and found (with the battery plugged in) by the Bluetooth driver of the BT adapter of the PC. The device name to display the GSV-6BT after it has been found is the same as the serial number of the device indicated on the nameplate. Some drivers may need to search manually for the supported services; SPP (BT classic) and BT-LE are supported.

To use the Windows program GSVmultichannel, e.g. for configuration, the BT driver for SPP must create a virtual COM port whose number should be known (otherwise look in the Windows Device Manager), so that the program can connect to the GSV-6BT. Click on the button "Add Channel".

The BT device search process does not need to be repeated later if the same device copy is reopened with the same PC, and the COM port number will remain the same. If the host PC or another GSV-6BT copy is changed, the search must be carried out again.

After connecting to the software or opening the COM port, the GSV-6BT is fully turned on, the blue LED that indicates the active BT connection is lit as well as the green that indicates that the GSV-6CPU analog amplifier electronics are on.

With GSVmultichannel can be configured among many other things whether the GSV-6CPU should remain switched on after closing the BT connection or not. If it is off, this saves battery charge, if it is on, e. g. the measurement data can be permanent recorded.

This and other Bluetooth-specific settings can be found in the program below:

Menu bar → Device → Advanced Settings → Interface → Bluetooth Settings

Settings for recording can be found here:

Menu bar → Device → Advanced Settings → Administration → Measuring Value Logger → Settings

There you can also open a file browser for the GSV-6BT SD card.

GSVmultichannel also provides a context help, which can be activated in the main window via Menubar -> Help.

After the first or new connection of the battery (Li-ion battery), the real-time clock should be reset. This is especially important when measuring data is to be recorded on an SD card. When you first turn it on after plugging in a new battery or when it has been recharged and completely empty, the red GSV6 LED flashes quickly ¹.

With GSVmultichannel the real-time clock can be set here:

Menu bar → Device → Advanced Settings → Administration

On the right side under "Device RTC time" click on the button next to the date / time display and then select "Set time to now", confirm with OK.

GSVmultichannel can also be used to reset one of the two operating hours counters at the same location. The operating hours counters work independently of the RTC.

¹ it start with device software version 3.17



The functions of the data logger and the frequency / tachometer or counter are described in separate documents which can be downloaded from the product / shop page at www.me-systeme.de.

For self-programming users, a Windows function library (MEGSV8w32.dll) with annotated C header is available and for programming with LabView © a library with wrapper VIs for this DLL.

For the use of the GSV-6BT in energy-saving mode "Bluetooth LE" Windows app is available.

Current consumption

			59 sec. GSVonoff=2 Timeintervall>0 Period Logger seconds	2 min. GSVonoff=2 Timeintervall=0 Period Logger Minutes
BT LE BTmode=0	GSV off	1,2 mA	1,2 mA	1,2 mA
	GSV on	53 mA	48 mA	48 mA
BT Classic SPP BTmode=1	GSV off	0,78 mA	0,78 mA	0,78 mA
	GSV on	62,3 mA	48,7 mA	49,1 mA

After the mode change from BT-Classic to BT-LE: 0.78 mA

After the mode change from BT-LE to BT-Classic: 1.2 mA

Sensor connection

To correctly display and record physical values, the measurement amplifier must be configured based on the connected sensor. If the sensor on Channel 1 is equipped with TEDS and wired properly, it will take over the sensor configuration stored in the TEDS data. This includes the system scaling ("AnalogOutScale"), the user scaling and the unit. The use of TEDS can be deactivated in GSVmultichannel under menu bar -> sensor -> TEDS ... In this dialog the TEDS data can also be read and displayed.

Sensors without TEDS can be configured with GSVmultichannel via the Configuration tab -> Input Type and -> Scaling.

Pin assignment

The connection of the sensors, the rechargeable battery and the voltage for charge / trickle charging of the rechargeable battery is done via solder pads.

For the configuration, solder bridges are closed, e.g. for configuring the inputs of the inputs for strain gage half bridges or strain gage quarter bridges

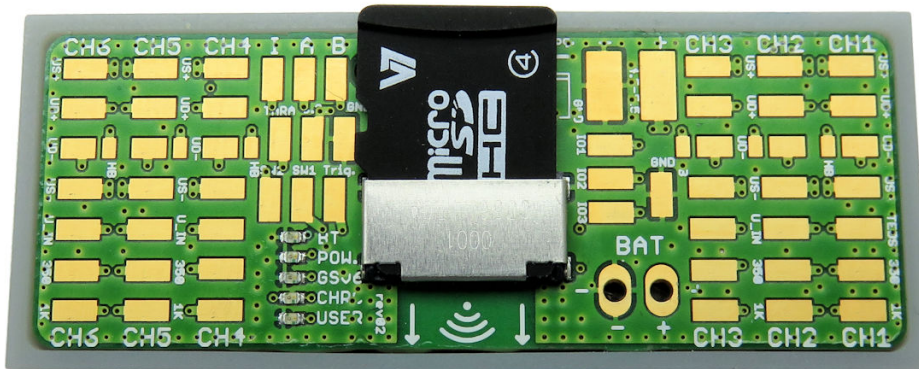
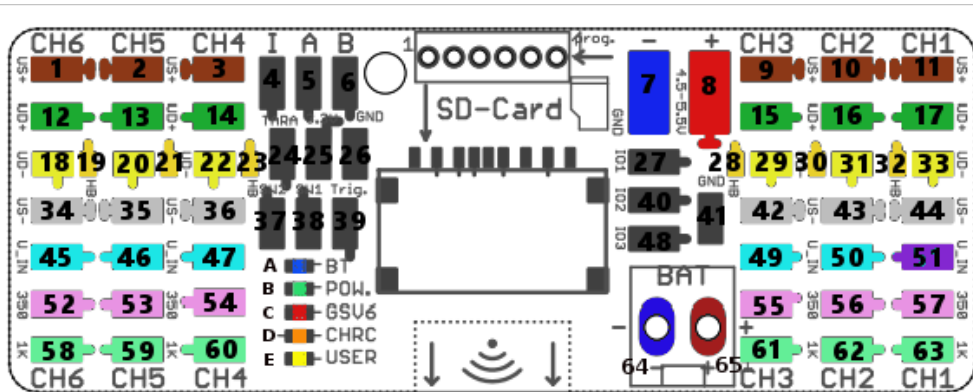

Strain gauge full bridges

Designation	Ch 1	Ch 2	Ch 3	Ch 4	Ch 5	Ch 6
positive bridge supply US+	11	10	9	3	2	1
positive bridge output UD+	17	16	15	14	13	12
negative bridge output UD-	33	31	29	22	20	18
negative bridge supply US-	44	43	42	36	35	34

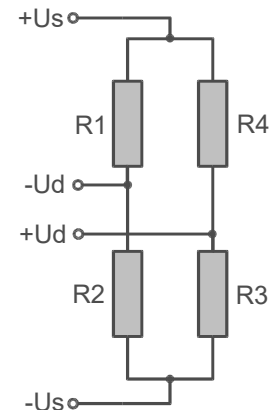

SG half bridges

Designation	Ch 1	Ch 2	Ch 3	Ch 4	Ch 5	Ch 6
Positive bridge supply US+		10	9	3	2	1
Positive bridge supply UD+		16	15	14	13	12
Negative bridge output UD-		31	29	22	20	18
half bridge		30	28	23	21	19
Negative bridge supply US-		43	42	36	35	34

The active strain gauges R3 and R4 are connected to the terminals +Us, +Ud and -Us.

The internal half-bridge R1, R2 is activated with a bridge from HB to -Ud.

[Ch1: 32-33, Ch2: 30-31, Ch3: 29-28, Ch4: 22-23, Ch5: 20-21, Ch6: 18-19]

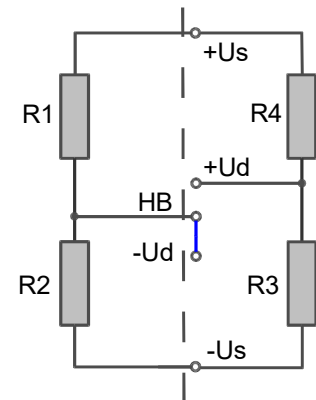

SG quarter bridge

Designation	Ch 1	Ch 2	Ch 3	Ch 4	Ch 5	Ch 6
Positive bridge output UD+		16	15	14	13	12
negative bridge supply UD-		31	29	22	20	18
half bridge		30	28	23	21	19
positive bridge supply US-		43	42	36	35	34
350 Ohm quarter bridge Q350		56	55	54	53	52
1000 Ohm quarter bridge Q1k		62	61	60	59	58

The active strain gauge R3 is connected in 3-wire technology to the terminals +Ud, QB and -Us.

The internal half-bridge R1, R2 is activated with a bridge from HB to -Ud.

[Ch1: 32-33, Ch2: 30-31, Ch3: 29-28, Ch4: 22-23, Ch5: 20-21, Ch6: 18-19]

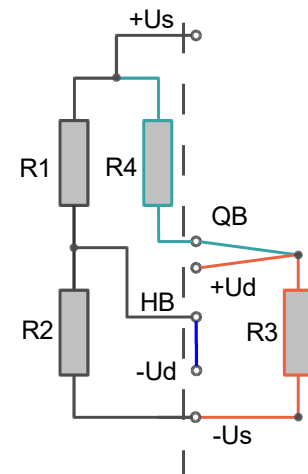

voltage input UE 0-10V

Designation	Ch 1	Ch 2	Ch 3	Ch 4	Ch 5	Ch 6
Negative bridge supply US-	-	43	42	36	35	34
voltage input UE	-	50	49	47	46	45

The analog input UE (single ended) measures voltages 0 ... 10V with respect to the US. The potential of US corresponds to the potential of the negative battery voltage.



Input for incremental encoder

Designation	No.
incremental encoder / I_index (Home/Index/Z)	4
incremental encoder / A-signal	5
incremental encoder / B-signal	6

Battery and maintenance charging

Designation	No.
Battery charging connection ground	7
Battery charging port 4,5 – 5,5V 0,5A	8
Battery negative pole	64
Battery positive pole	65
Tare (Zero Setting) in order to release of TARE, connect with GND (Solder pad 26) for at least 2s	24

Auxiliary voltage supply for active sensors

Designation	No.
3,3 V Voltage output (10mA max)	25
GND	26

Digital inputs and outputs

Designation	No.
Threshold output 2	37
Threshold output 1	38
Trigger input	39
IO_1 / PB4 BT121	27
IO_2 / PB5 BT121	40
GND_IO	41
IO_3 / PB6 BT121	48
TEDS communication-pin	51

Function of the LEDs

Designation	Description	Nr.
BT	Bluetooth Status: On: connected	A
POW.	GSV-6CPU On/Off	B
GSV6	GSV-6CPU Status: flash codes, e.g. for TEDS. constantly on / slowly flashing: File open on SD card for writing. Do NOT remove the card!	C
CHRG	Battery charging indicator	D
USER	IO_4 per BGscript freely programmable LED	E



Changelog

version	date	amendments
ba-gsv6bt-v1.0.odt	25.02.18	First german version (Kab)
ba-gsv6bt-v1.1.odt	05.03.18	description extended (SW)
ba-gsv6bt-v1.2.odt	02.04.18	Power consumption added (Kab)
ba-gsv6bt-v1.3	03.04.18	Added (SW)
ba-gsv6bt-v1.0-en.odt	13.06.18	first english version (AE)
ba-gsv6bt-v1.3-en.odt	19.06.18	english version edited and added contents (AK)
ba-gsv6bt-v1.4-en.odt	28.06.19	At channel 1: only Fullbridges; typos

Änderungen vorbehalten.
Alle Angaben beschreiben unsere Produkte in allgemeiner Form.
Sie stellen keine Eigenschaftszusicherung im Sinne des §459 Abs. 2, BGB, dar
und begründen keine Haftung.

Made in Germany

Copyright © 2019
ME-Meßsysteme GmbH
Printed in Germany