

Product	Contacts: 4, cable outlet: 4-6 mm, cable plug connector, shieldable, screw terminal connection, static ring version with die-cast threaded ring, UL approval
Area	M12-A Series 713
Article number	99 1429 814 04

Illustration

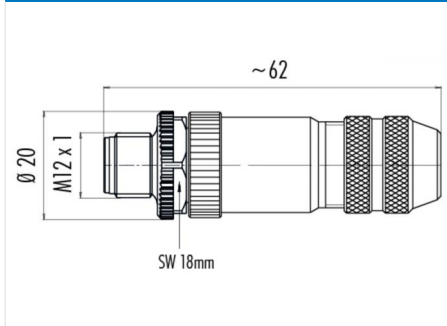

Scale drawing



Contact Arrangement

	X	Y
1	2,50	0,00
2	0,00	2,50
3	-2,50	0,00
4	0,00	-2,50

Attenuation characteristic

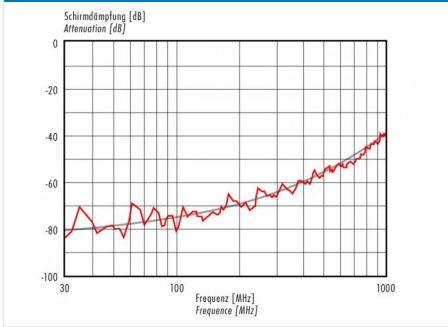

You can find the item description and assembly instruction on the next page.

Technical data

General features

Connector Design	Cable Connector
Connector locking system	bolted screw
Termination	screw
Wire gauge (mm)	0,75 mm ²
Wire gauge (AWG)	18
Cable outlet	4 – 6 mm
Upper temperature	85 °C
Lower temperature	-40 °C

Cable data

Approval 1	UL
------------	----

Electrical parameters

Rated voltage	250 V
Rated impulse voltage	2500 V
Pollution degree	3
Overvoltage category	II
Material group	II
Rated current (40°C)	4 A
Volume resistivity	≤ 3 mΩ
EMV compliance	shieldable
Degree of protection	IP67
Mechanical operation	> 100 Mating cycles

Material

Material of contact	CuZn (Messing)
Contact plating	Au (gold)
Material of contact body	PA

Product	Contacts: 4, cable outlet: 4-6 mm, cable plug connector, shieldable, screw terminal connection, static ring version with die-cast threaded ring, UL approval
Area	M12-A Series 713
Article number	99 1429 814 04

Item description

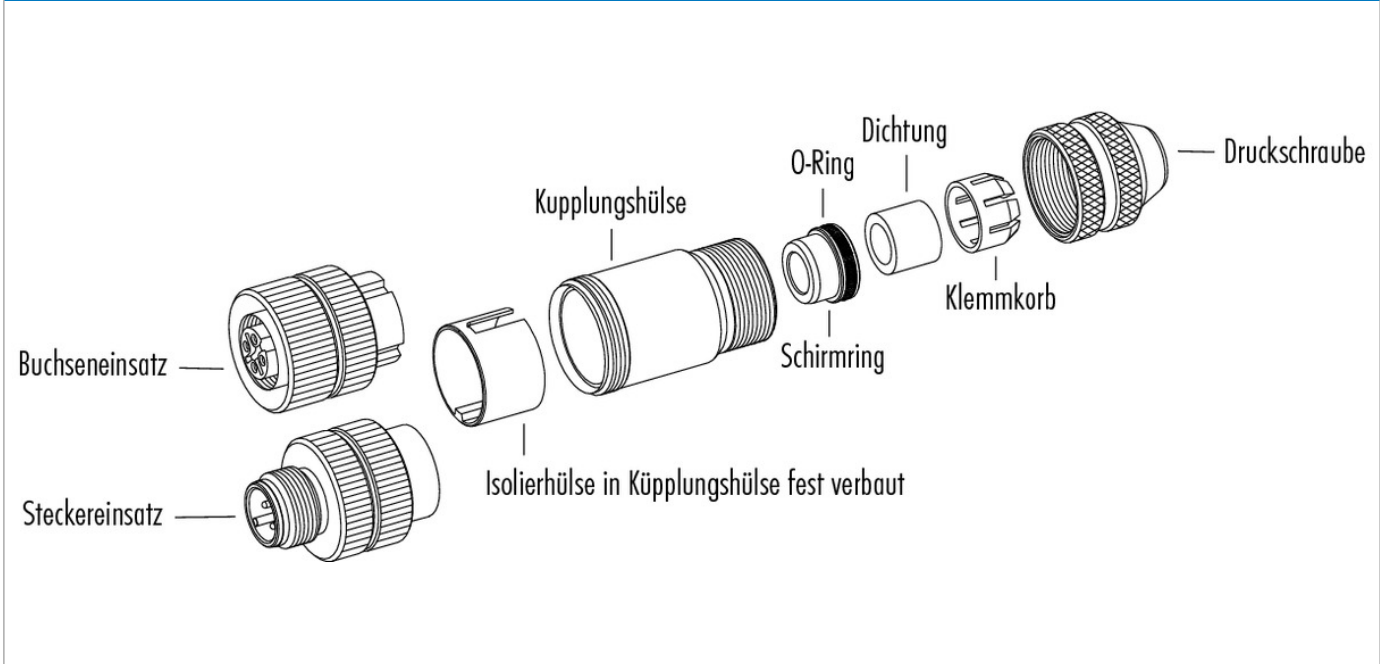

Installation instructions / Mounting cutout

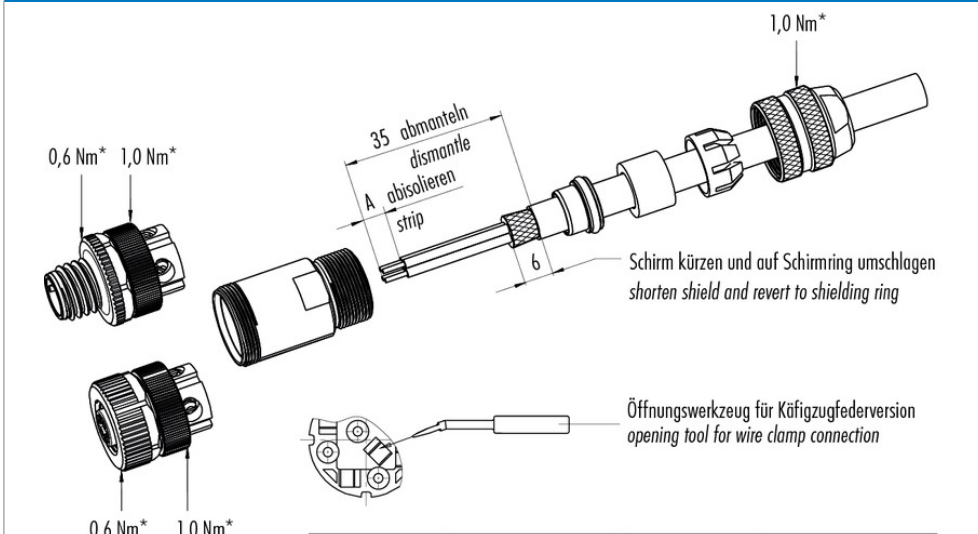

1. Teile auffädeln.
2. Abisolieren, Schirm kürzen und auf Schirmring umschlagen.
3. Litzen durch Gehäuse fädeln, Schirmring, Dichttring, Klemmkorb montieren. Druckschraube andrehen, um das Kabel zu fixieren. Litzen anschrauben.
4. Gehäuse mit Stecker- bzw. Buchseneinsatz verschrauben und Druckschraube festdrehen.

1. Bead parts.
2. Strip single cores, shorten shielding braid and revert to shielding ring.
3. Thread single wires through housing, mount shielding ring, seal and pinch ring. Turn on pressing screw to fix the cable. Screw on single wires.
4. Screw housing to male or female contact insert and fix pressing screw.

	Schraubklemmversion screw connection	Lötversion solder version	Käfigzugfederverision wire clamp connection
Maß A/mm measure A/mm	4	3,5	7

* Empfohlenes Anzugsdrehmoment
Recommended tightening moment