

DA54-tiewrap PUR/10S/140 0,1µm/m bis 1300µm/m



Description

The strain sensors DA54-mag, DA54-tiewrap are suitable for high-resolution detection of forces and deformation of structural works such as bridges, silo legs, offshore wind farms, railway lines, etc.

With these models in an anodised aluminium housing, the same performance features are achieved as when applying strain gauges (DMS) directly. These features include a high resolution, very low drift effects and the options for both static and dynamic measurement. The strain sensor includes a completely wired DMS that is pressed onto the component by a specially formed pressing mechanism when screwing on the extension sensor. An integrated seal provides an initial layer of protection against dust and damp. Depending on the planned duration of use, measures to protect against damp, such as waterproofing the joints with silicone, encapsulation with additional surrounding hoods, etc. are applied after installation.

Unlike strain sensors DA40 and DA54, the pressure strength is generated by integrated high-performance magnets or cable ties. Time-consuming drilling of threads is not required as a result.

The strain sensors are equipped with different strain gauges depending on the application. Type FAE4 and FAED4 full bridges and FAET and FAED half bridges or FAE single grids are used.

Dimensions

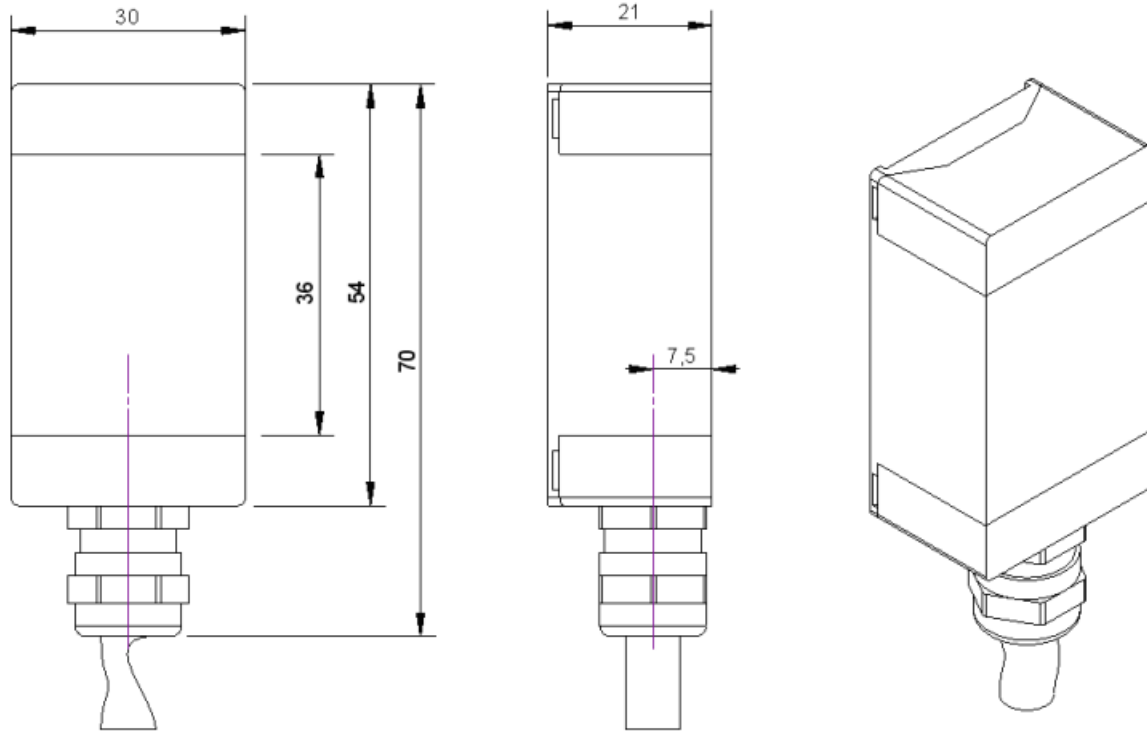

Technical Data

Basis Data

Type	Dehnungsaufnehmer
Nominal strain	1300 $\mu\text{m/m}$
Operating strain	150 %Fn

Electrical Data

Input resistance	350 Ohm
Tolerance input resistance	7 \pm
Output resistance	350 Ohm
Tolerance output resistance	7 \pm
Insulation resistance	5x10 ⁹ Ohm
Rated range of excitation voltage f	2.5 ... 5 V
Operating range of excitation voltage f	1 ... 5 V
Zero signal	2 mV/V

Precision

Temperature effect on zero signal	0.005 mV/V/10K
Temperature effect on characteristic value	1 %v.S./10K

Connection Data

Connection type	4 conductor open
Name of the connection	2x2x0,25 PUR
Cable length	15 m

Temperature

Rated temperature range f	-10 ... 65 °C
Operating temperature range f	-20 ... 85 °C
Storage temperature range f	-20 ... 85 °C
Environmental protection	IP65

Strain gauge is used with k-factor = 2.



Pin Configuration

Symbol	Description	Wire colour
+Us	positive bridge supply	brown
-Us	negative bridge supply	white
+Ud	positive bridge output	green
-Ud	negative bridge output	yellow

Screen - transparent.

Pressure load: positive output signal

accessories

Description	Description
 M-Bond-31	gelatinous, 2-component adhesive in 50 ml double cartridge, 50ml Methacrylate, 50ml Hardener; Operating temperature -55 ° C ... 120 ° C
 Mixing-tool Pack10	Mixing nozzles for double cartridge 50g M-Bond-30 and M-Bond-31; package of 10;
 WS-14	Dispensing gunl for 37ml and 50ml double cartridges.