

## KD80se ±100N/010-5



### Description

The force sensor KD80se is used for tensile and compressive force measurements and for weighing.

The areas of application are e.g. wire rope measurements, test beds, overload securing for lifting tools, process controllers as well as weighing scales.

The sensor with integrated analog amplifier GSV-13q is a compact measuring system. The electronics amplifies the strain gage output signal, and allows a simple and direct analog measurement in voltage (0... 10V).

Further variants for voltage (0... 5V) or current (4... 20mA) are available on request.

The force sensor KD80se for the standard temperature range will be delivered with cable Unitronic FD CP Plus.

The KD80se sensors have accuracy class of 0.05%. The environmental protection is IP65.

## Dimensions

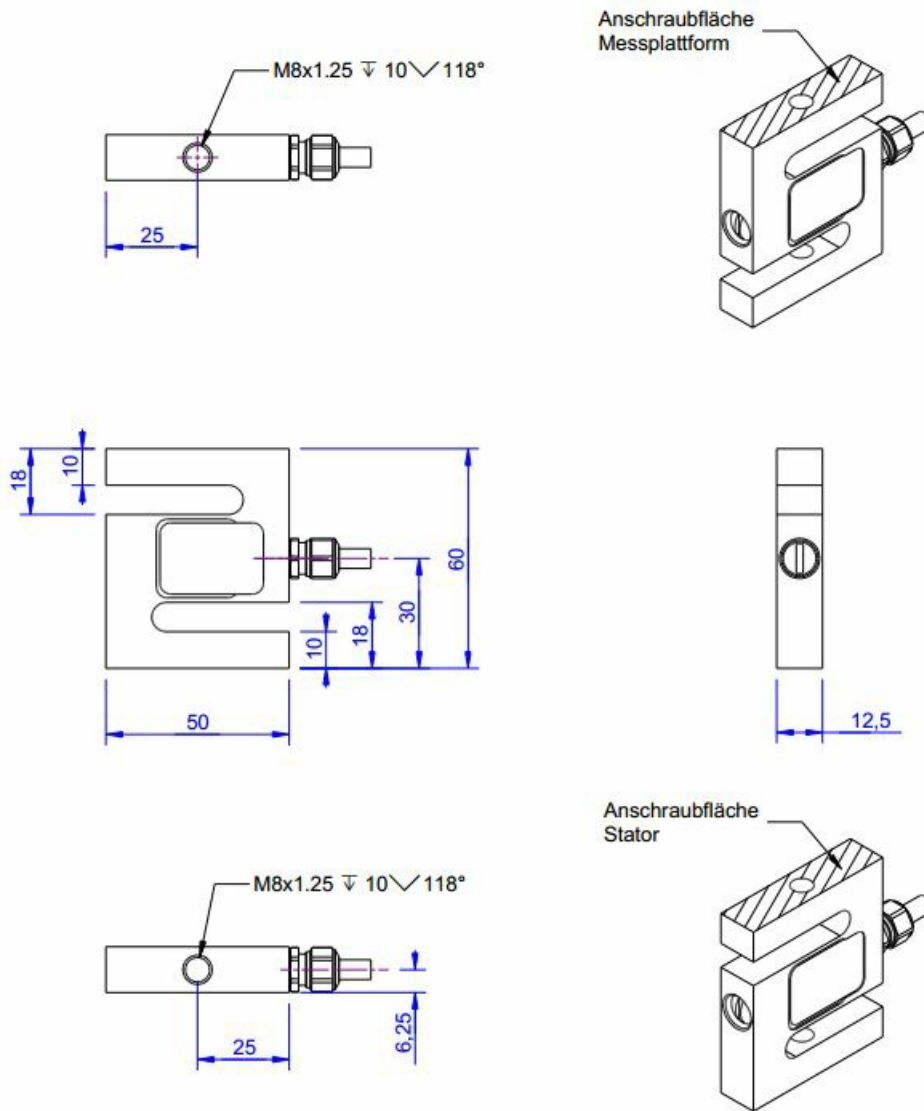

## Technical Data

### Force sensor

Type	Force sensor
Force direction	Tension / Compression
Rated force F <sub>x</sub>	100 N
Force introduction	Inner thread
Dimension 1	M8x1,25
Sensor Fastening	Inner thread
Dimension 2	M8x1,25
Operating force	150 %FS
Rated displacement	0.2 mm
Lateral force limit	100 %FS
Material	Stainless steel
Natural frequency	5 kHz
Height	60 mm
Length or Diameter	50 mm

### Measuring frequency

Limit frequency (analog)	1000 Hz
--------------------------	---------

### Precision

Accuracy class	0,05%
Relative linearity error	0.02 %FS
Relative zero signal hysteresis	0.02 %FS
Temperature effect on zero signal	0.02 %FS/K
Temperature effect on characteristic value	0.01 %RD/K
Relative creep	0.1 %FS

### Supply

Supply voltage f	14 ... 28 V
Current consumption from	40 mA

### Connection Data

Name of the connection	Unitronic FD CP Plus 3x2x0,14
------------------------	-------------------------------

### Temperature

Rated temperature range f	-10 ... 70 °C
Operating temperature range f	-10 ... 85 °C
Storage temperature range f	-10 ... 85 °C
Environmental protection	IP65

### Basis Data

Number of channels	1-Kanal
--------------------	---------

Abbreviation: RD: „Reading“; FS: „Full Scale“;





1) *The exact nominal sensitivity is indicated in the test report;*

## Pin Configuration

Symbol	Description	Wire colour
Ub	Supply voltage (depends on variant)	brown
GND	Ground power supply	white
Ua (Out)	Output signal 4... 20mA / 0... 10V / 0... 5V	green
Tara (Ta)	Control input for zero balance	yellow
Scale (Sc)	Control input for amplification factor	grey
GND	Ground, signal	pink
	Shield	transparent

## accessories

Description	Description	
	Configuration amplifier	As a free service, we offer the setting of calibration factors in the memory of the measuring amplifier
	Calotte screwable	Screwable stop pin for force introduction for sensors KDs;