

K6D175 50kN/5kNm/UP13



Description

The K6D175 multi-axis sensor is designed for measuring force and torque in three mutually perpendicular axes.

The measurement ranges for the forces and moments can be factory adapted in a wide range. The K6D175 was developed for the following applications:

- Robotics
- Measurements in automation technology.

The force and torque loadings are evaluated e.g. using GSV-8DS SubD44HD or GSV-8AS measurement amplifier. The 6 load values can be calculated using a Windows DLL or using LabVIEW with the aid of a digital calibration document provided.

The calibration document contains the individual calibration factors and error corrections for the sensor.

Dimensions

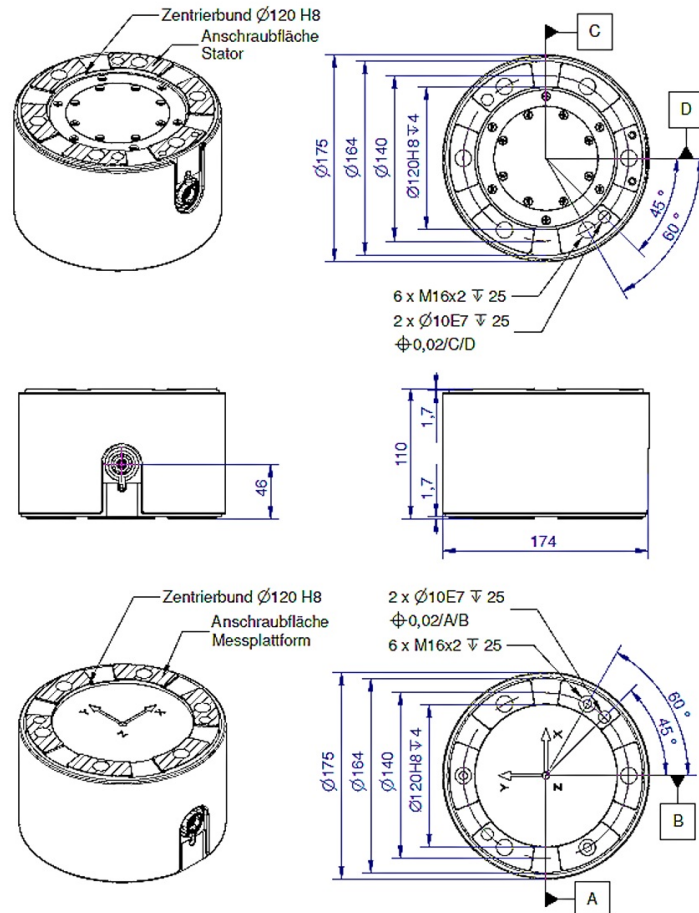

Technical Data

Force sensor

Type	6-Axis force sensor
Force direction	Tension / Compression
Rated force Fx	50 kN
Rated force Fy	50 kN
Rated force Fz	100 kN
Force introduction	Inner thread
Dimension 1	6x M16x2
Sensor Fastening	Inner thread
Dimension 2	6x M16x2
Operating force	200 %FS
Rated displacement	0.1 mm
Twist	0.01 rad
Material	Stainless steel
Natural frequency	2.3 kHz
Dimensions	Ø175 x 110 mm
Height	110 mm
Length or Diameter	175 mm
Rated torque Mx	5 kNm
Rated torque My	5 kNm
Rated torque Mz	10 kNm
Torque limit	300 %FS
Bending moment limit	300 %FS

Electrical Data

Input resistance	350 Ohm
Tolerance input resistance	10 Ohm
Output resistance	350 Ohm
Tolerance output resistance	10 Ohm
Insulation resistance	2 GOhm
Rated range of excitation voltage f	2.5 ... 5 V
Operating range of excitation voltage f	1 ... 10 V
Zero signal to	-0.05 mV/V
Zero signal from	0.05 mV/V
characteristic value range min	0.45 mV/V
characteristic value range max	0.7 mV/V

Precision

Accuracy class	0,5%
Relative linearity error	0.1 %FS
Relative zero signal hysteresis	0.1 %FS
Temperature effect on zero signal	0.1 %FS/K
Temperature effect on characteristic value	0.05 %RD/K
Relative creep	0.1 %FS
Relative repeatability error	0.5 %FS



Connection Data

Connection type	Connector
Name of the connection	Rundsteckverbinder UP13

Eccentricity and Crosstalk

Crosstalk	1 %FS
-----------	-------

Temperature

Rated temperature range f	-10 ... 70 °C
Operating temperature range f	-10 ... 85 °C
Storage temperature range f	-10 ... 85 °C
Environmental protection	IP65

Abbreviation : RD: „Reading“; FS: „Full Scale“;

The application of a calibration matrix is required for the determination of the forces F_x , F_y , F_z and moments M_x , M_y , and M_z from the 6 measurement channels, and to compensate for the crosstalk.

The calibration data are individually determined and documented for the sensor.

The measurement error is expressed individually by the specification of the extended measurement uncertainty ($k = 2$) for the forces F_x , F_y , F_z , and moments M_x , M_y , M_z .

Pin Configuration

Channel	Symbol	Description	Wire colour	PIN
1	+Us	positive bridge supply	yellow	14
	-Us	negative bridge supply	green	13
	+Ud	positive bridge output	white	1
	-Ud	negative bridge output	brown	5
2	+Us	positive bridge supply	gray	15
	-Us	negative bridge supply	black	16
	+Ud	positive bridge output	red	7
	-Ud	negative bridge output	pink	6
3	+Us	positive bridge supply	brown-blue	23
	-Us	negative bridge supply	white-red	24
	+Ud	positive bridge output	brown-red	12
	-Ud	negative bridge output	white-pink	4
4	+Us	positive bridge supply	white-yellow	13
	-Us	negative bridge supply	yellow-brown	20
	+Ud	positive bridge output	brown-green	9
	-Ud	negative bridge output	white-green	3
5	+Us	positive bridge supply	white-gray	21
	-Us	negative bridge supply	white-blue	22
	+Ud	positive bridge output	gray-brown	10
	-Ud	negative bridge output	pink-brown	11
6	+Us	positive bridge supply	gray-pink	18
	-Us	negative bridge supply	purple	17
	+Ud	positive bridge output	red-blue	8
	-Ud	negative bridge output	blue	2
-	shield		transparent	

Shield: connected with sensor housing;

Manual

Stiffness Matrix K6D175 10kN/1kNm

178.1 kN/mm	0,0	0,0	0,0	10331 kN	0,0	u_x
0,0	178.1 kN/mm	0,0	-103314 kN	0,0	0,0	u_y
0,0	0,0	786.7 kN/mm	0,0	0,0	0,0	u_z
0,0	-10331 kN	0,0	2149.7 kNm	0,0	0,0	ϕ_x
10331 kN	0,0	0,0	0,0	2149.7 kNm	0,0	ϕ_y
0,0	0,0	0,0	0,0	0,0	1404.3 kNm	ϕ_z

Stiffness Matrix K6D175 20kN/2kNm

375.5 kN/mm	0,0	0,0	0,0	21800 kN	0,0	u_x
0,0	375.5 kN/mm	0,0	-21800 kN	0,0	0,0	u_y
0,0	0,0	1658.3 kN/mm	0,0	0,0	0,0	u_z
0,0	-21800 kN	0,0	4531.7 kNm	0,0	0,0	ϕ_x
21800 kN	0,0	0,0	0,0	4531.7 kNm	0,0	ϕ_y
0,0	0,0	0,0	0,0	0,0	4844.0 kNm	ϕ_z

Stiffness Matrix K6D175 50kN/5kNm

614.4 kN/mm	0,0	0,0	0,0	35600 kN	0,0	u_x
0,0	614.4 kN/mm	0,0	-35600 kN	0,0	0,0	u_y
0,0	0,0	2713.6 kN/mm	0,0	0,0	0,0	u_z
0,0	-35600 kN	0,0	7415.4 kNm	0,0	0,0	ϕ_x
35600 kN	0,0	0,0	0,0	7415.4 kNm	0,0	ϕ_y
0,0	0,0	0,0	0,0	0,0	4844.0 kNm	ϕ_z

Element	Description
[kN/mm]	force- displacement
[kNm]	torque- twist
[kN]	force- twist and torque- displacement





Mounting

The force is applied to an annulus/to 6 segments of a circle, 155 mm – 140 mm in diameter, on the end faces of the sensor. No force is applied to the area inside the 140 mm in diameter ring.

The areas outside the annuli can be used for centring purposes. A centring hole is provided to secure the angular position.

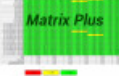
Recommended tightening torque: 250Nm.

accessories

Description	Description
 K6D-CalibrationMatrix HL	Standard calibration matrix "High load" for the sensors with big measuring ranges
 K6D-CalibrationMatrix HL/Plus	High accuracy calibration matrix for 6-axis force/torque sensors;
 GSV-8DS	8-channel amplifier with USB port, analog output, UART interface. Other versions GSV-8AS CAN with Canbus and GSV-8AS EC with EtherCAT fieldbus.
 K6D-Adapter Development	Indicative offer for an adapter set, Consisting of e.g. 2 plates, For mounting a device / flange on K6D sensor;
 Connection cable UP13/27p/m/90°-D-Sub44HD/m	Connection cable for connecting the K6D sensor to an 8-channel measuring amplifier GSV-8DS SubD44HD