

## GSV-3USB 2mV/V



### Highlights

- Powered via USB port
- Sampling rate 10 kHz
- Data rate 1...1000 Hz
- straingage quarter, half, full bridges
- Built-in bridge supplement 350 Ohm
- Optionally also for displacement transducers
- Comprehensive software support
- Galvanic isolation to USB port
- Optional for connection of torque sensors with incremental encoder

## Description

This measuring amplifier for sensors with wire strain gauges is equipped with a USB interface, while power is supplied via the USB port on the rear of the measuring amplifier.

The measuring amplifier is also available in a 2-channel version (GSV-3USBx2).

A 15-pole Sub-D socket is included for connecting sensors.

The dual-channel measuring amplifier features sensor connections via two round plug connectors.

The measuring amplifier GSV-3USB is ideal for mobile use, because the aluminum housing (protection class: IP54) is very compact.

The high limiting frequency of 1250 Hz is suitable for the detection of static and dynamic signals from sensors with strain gauges.

The stand-out features include its high sampling rate of 10kHz and the high 16 bit resolution, as well as the exceptional command set provided to configure the measuring amplifier via ASCII control codes or a Windows DLL.

This measuring amplifier can also be configured via solder bridges when analysing strain gauge quarter bridges (e.g. 350 ohm) or for a power supply of  $\pm 10$  V.

It can also be optionally supplied for connecting potentiometric displacement transducers or for power input of 4...20mA, as well as for incremental encoders.

## Technical Data

### Input analog

Number of analog inputs	1
Input sensitivity-steps	2.0 mV/V

### Output analog

Number of analog outputs	1
Voltage output f	0 ... 5 V

### Measuring frequency

Data frequency f	1 ... 1000 Hz
Sampling frequency	10 kHz
Limit frequency (analog)	1250 Hz

### Supply

Supply voltage f	4.5 ... 5.5 v
Current consumption from	120 mA
Strain gauge bridge supply	4.2 V

### Interface

Type of the interface	usb
Quantity of the interface	1
Version of the interface	USB 2.0

### Zero adjustment

Tolerance	5 mV
Time period	90 ms
Debouncing time	4 ms
Trigger level f	3.5 ... 30 V
Trigger edge	falling

### Temperature

Rated temperature range f	-10 ... 65 °C
Operating temperature range f	-40 ... 85 °C
Environmental protection	IP40

### Basis Data

Dimensions	126 x 85 x 25 mm
Housing	Aluminium
Connection	Connector
Number of channels	1-Kanal

### Precision

Accuracy class	0,1%
----------------	------



Relative linearity error	0.02	%FS
Temperature effect on the zero point	0.1	%FS/10°C
Temperature effect on the measuring sensitivity	0.1	%RD/10°C
Resolution	16	Bit

## Mounting

### Pin connection (full, half, quarter bridges, displacement sensors)

Sub-D socket, 15 pole, or 5-pole socket M12x1, type 763

Overview:

For threshold pick-ups:

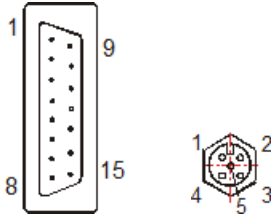

15-pol.	5-pol.	Description	Colour code for cable	
1		GND ( = -U <sub>S</sub> )	Shielding	
5	2	-U <sub>S</sub> negative bridge supply	white	white
6	1	+U <sub>S</sub> positive bridge supply	brown	brown
8	3	+U <sub>D</sub> positive differential input	green	blue
15	4	-U <sub>D</sub> negative differential input	yellow	black
14	5	AUXin customisable input	grey	grey
2		TARA control input fro zero setting function		
3		VCC_T voltage 5,6V DC, 1mA		
9		A <sub>out</sub> Analog output 0,1V...4,8 V		
10		SW threshold switch		

- In the 1-channel GSV-3USB, the shield is connected to PIN 1.
- In the 2-channel GSV-3USBx2 with a round plug connector, the shield is placed on the plug housing.
- 
- Alternatively, the shield is placed on PIN 2 of the round plug connector

### Connection diagram for quarter bridges and half bridges

Please note: When connecting quarter or half bridges, the measuring amplifier must be correctly configured. Closing two solder bridges connects together the three additional resistors.

Wire strain gauge-quarter bridges are connected using three-wire technology, which reduces the impact of the supply cable on the zero point, and halves zero point drift.

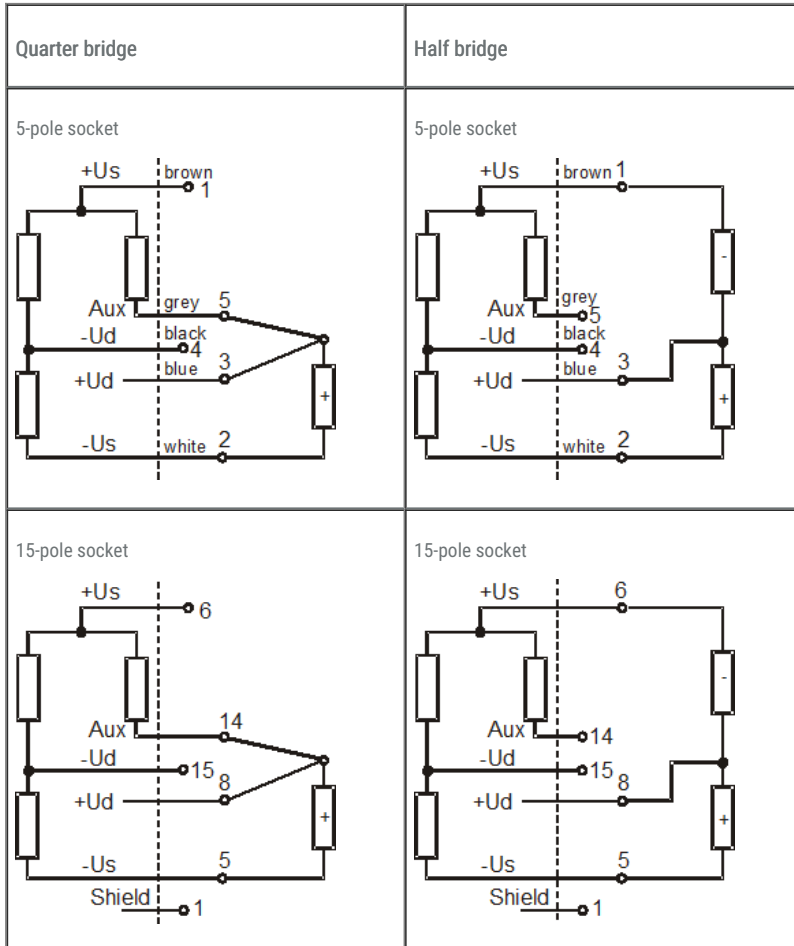

### Connection diagram for potentiometric travel sensors

The GSV-3USB and GSV-3USBx2 measuring amplifiers are available in a design for connection to potentiometric travel sensors (linear potentiometer or tackle way receiver), which involves the slider of the travel sensor being connected to the "Aux" input of the measuring amplifier.

The travel sensor is powered via the sensor power supply +Us and -Us.

The power supplied to the potentiometric travel sensor is at 4.2V.

The input scope includes the ability to handle voltages of 0...4.2V.

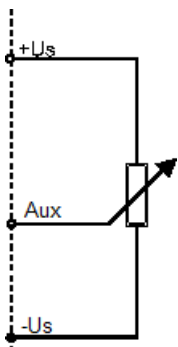

Pin connection

Designation	5-Pol. socket GSV-3USB	15-pol. SUB-D socket GSV-3USB
positive supply +Us	1	6
negative supply -Us	2	5
input „Aux“	5	14

#### Connection of the Way Con – cable sensor SX terminal assignment for voltage input

Designation	5-Pol. socket GSV-3USB	15-pol. SUB-D socket GSV-3USB
±10 Volt	3	8
Measuring signal ground	4	15
Shield	Housing	1

#### Pin connection for current input

Designation	5-Pol. socket GSV-3USB	15-pol. SUB-D socket GSV-3USB
±20 mA	3	8
Measuring signal ground	4	15
Shield	Housing	1

#### Connection for hall switch on special models for speed measurement

GSV-3USB and GSV-3USBx2 measuring amplifiers are available in models capable of measuring speed. This involves the connection of a hall switch as a sensor, which is triggered by one, two, four or eight magnets per revolution. The threshold level at which the speed measurement pulse is detectable is a change in the magnetic flow density from 20mT to 4mT, whereby the magnetic south pole must be facing the sensitive surface of the hall switch.

The unit must be configured to rpm and the output reading of the measurement values is set to text format by default. The default scaling is set to 20000 and cannot be changed. The number of magnets generating pulses on the hall sensor can be configured using gsvterm.exe. For this purpose, please use the menu option "Special settings" within the program interface on page 2.

#### Connection of the HAL501 hall switch

Function	5-pol. socket M12 GSV-3USBx2	15-pol. SUB-D socket GSV-3USBx1	HAL501, customised
Ground (GND), Shield	2	1	Brown (Pin2)
Supply +5V	1	3	White(Pin1)
Switching-signal	3	13	Green (Pin3)

Instead of the HAL501 hall switch, other transmitters with a power consumption under 5V, 5mA and an output signal with TTL Pegel can be connected. The use of a rod magnet NdFeB 20mmx10mmx4mm enables a working distance of up to 10mm between the hall switch and the magnet.

Number of magnets	Speed range in RPM		Response time in terms of number of rotations	
	Minimum	Maximum	Minimum	Maximum
1	18	36000	ca. 1	ca. 2
2	9	18000	ca. 1/2	ca. 1
4	4,5	9000	ca. 1/4	ca. 1/2
8	2,25	4500	ca. 1/8	ca. 1/4



Figure 3: Hall switch HAL501 within the TO92 housing, note the sensitive surface position (should be facing the magnetic south pole)

#### Connection of dual track pulse generators

GSV-3USB and GSV-3USBx2 measuring amplifiers are available in models capable of measuring rotation angle/speed or travel distance. For this purpose, an incremental pulse generator is connected, which emits phase-shifted square signals in the event of a change in travel distance or rotation angle through 90° (connections A and B).



Function	5-pol. socket M12 GSV-3 USBx2	15-pol. SUB-D socket GSV-3 USBx1
Ground (GND), Shield	2	1
Supply +5V	1	3
Pulse signal A	3	12
Pulse signal B	4	13

### Connection of a torque sensor DR-2335

A dual-channel measuring amplifier GSV-3USBx2 2mV/V/RPM/Sub-D15 is recommended for operating the DR2335 sensor.

Lines "A" to "M" of the DR2335 sensor are connected to the SubD-15 socket of the measuring amplifier.

### Configuration

Port „A“	Port „B“
„Log mode“ off	„Log-mode“ on
Scaling factor 2 mV/V or a corresponding factor calculated for the sensor parameter.	Scaling factor <b>31207.6</b> for the display in angular degrees. The resolution is 0.5°.

The data frequency is configured to port "A" . Port "B" transmits synchronously with the data frequency of port "A" .

Port "B" functions as an incremental counter and is not automatically reset to zero. After reaching the figure 65535°, it reverts to zero.

The command "SetZero" can be used to reset the counter to 0 at any time.

DR2335 signals	DR2335 12-pol. plug connector	GSV-3USB 5-pol M12 socket; Port „A“	GSV-3USB 5-pol M12 socket; Port „A“	GSV-3USB SubD15 socket; Port „A+B“
DMS Us+	B	1 (brown)		6
DMS Us-	A	2 (white)		5
DMS Ud+	C	3 (blue)		8
DMS Ud-	D	4 (black)		15
Counter +5V (Vcc)	F	-	1 (brown)	11
Counter GND	E and J (where applicable, connected)	-	2 (white)	7
Counter A	G	-	3 (blue)	12
Counter B	H	-	4 (black)	13
Shieldings	M	Cabel shield	Cable shield	1

The attainable signal/noise ratio depends on the ambient conditions (cable length, shielding), the configured data rate and the FIR filtration which can be optionally applied. The figure below shows the resolution with a connecting cable 1m in length, measurement range  $\pm 2\text{mV/V}$ , FIR filter switched off.

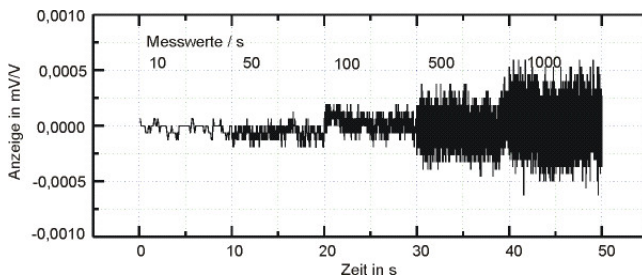

### Adapting the measuring amplifier

Using solder bridges on the platinum subsurface, the measuring amplifier can be configured into a range of operating modes. Two screws on the front side can be removed to open the housing. The screws are covered with black cover caps.

The measuring amplifier includes an add-on for quarter bridges with 350 ohm and this configuration can be activated using solder bridges. With the "quarter bridge / half bridge" configuration, half bridges are also connectable from 120 ohm.

Additional adaptations include voltage input  $\pm 10\text{V}$ , current input 4...20mA, input for potentiometer transmitters.

### Terminal assignment on the platinum subsurface

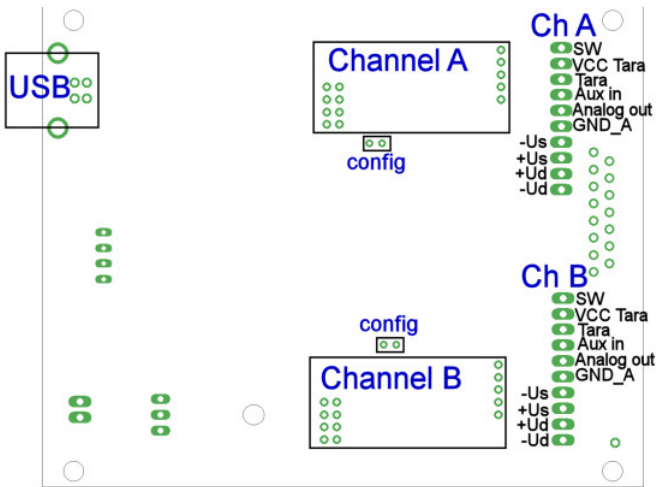

Figure 4: Pin assignment, platinum subsurface

srtaingauge full bridges

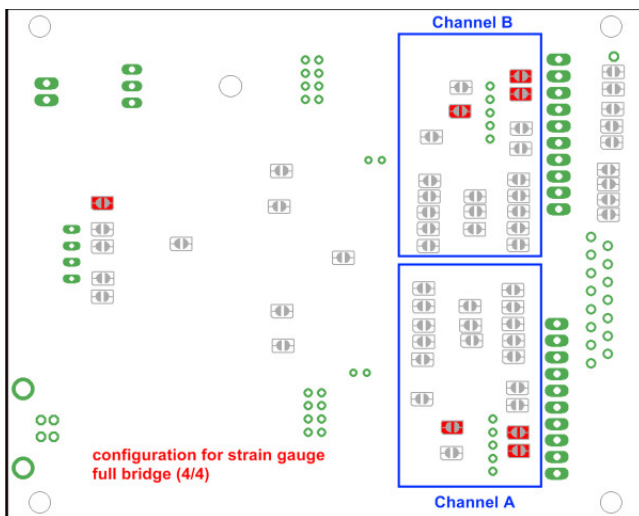

Figure 5: strain gauge full bridges

Straingauge quarter bridges

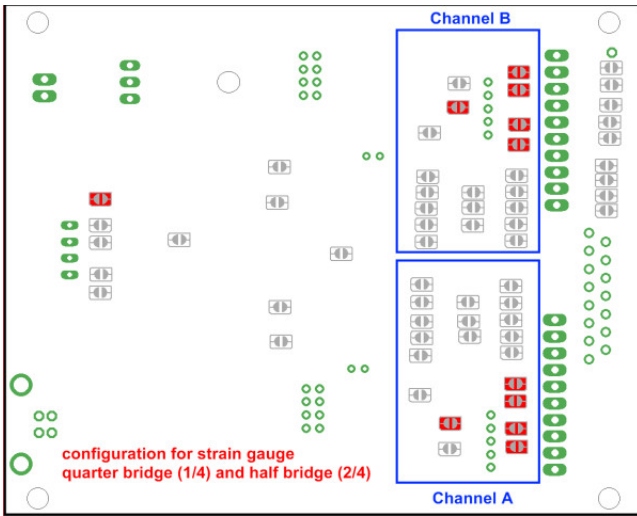

Figure 6: strain gauge quarter bridges 350 Ohm and half bridges (120 Ohm...5000 Ohm)

Potentiometric transmitter, displacement sensors

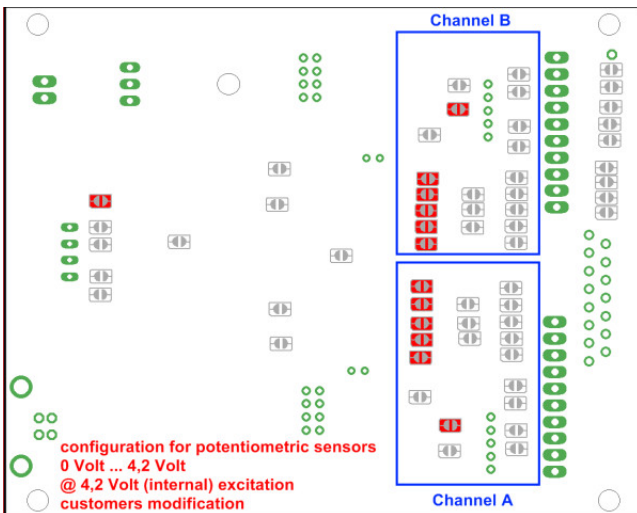

Figure 7: Potentiometric transmitter, displacement sensors

Voltage input -10V...+10V

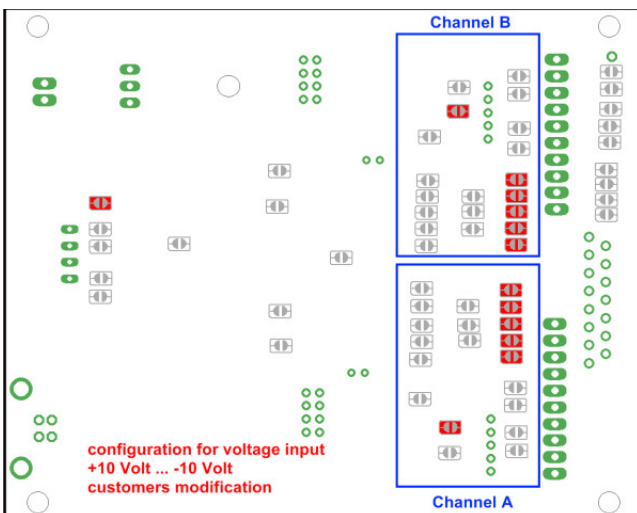

Figure 8: voltage input +10 Volt

Current input -20mA ...+20mA

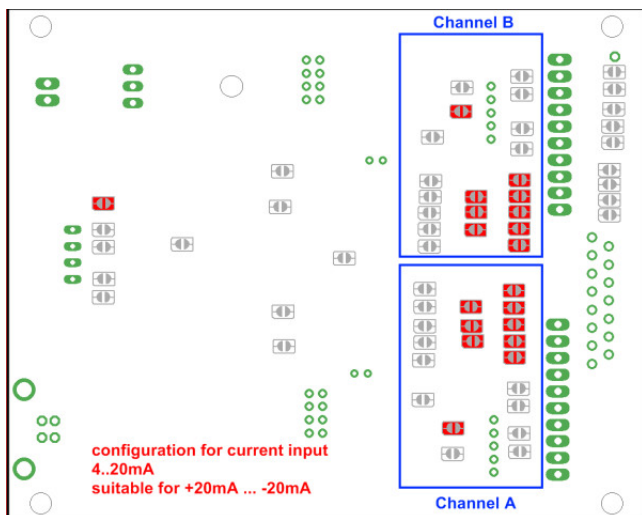

Figure 9: current input 4-20mA

### Advice for the USB interface

Switching on electrical devices (laboratory power supplies, power supplies, engines, heating coils, neon lights) can lead to the computer USB interface shutting down. In the event of any problems, the computer should be supplied via a isolating transformer or via a separate electrical circuit.

There are several ways of improving the reliability of the USB interface of the PC or laptop:

- Use a high-quality USB cable with a ferrite core,
- Reduce the number of USB devices used, since the overall current is limited to 500mA,
- Use an active (self-powered) USB hub,
- Use laptop power supplies with grounding.

The use of an active USB hub with its own power supply is particularly helpful for improving the reliability of the USB interface.



### Notes on the threshold pick-up

#### Threshold pick-up

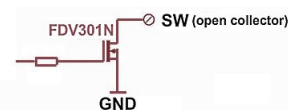
The transformer will trip if the limit value is exceeded. The maximum switching current is 200mA.



## accessories

	Description	Description
	Configuration SubD15/m	Connector Type SubD 15 pin, pins (male), with hood, terminated on Liycy 2x2x0.25, 1.5m as an extension of KR20 (threaded sockets in the Sub-D 15)
	Mounting-FEET-100	Mounting plates for GSV-3USB / GSV-3USBx2 / GSV-1A4 / GSV-4USB

## Order options

Type	Description
GSV-3USB 2mV/V	Input $\pm 2$ mV/V, 1x SubD15, (standard type, 95% of all sensors with strainage)
GSV-3USB 3,5mV/V	Input $\pm 3.5$ mV/V 1x SubD15, (e.g. for KD9363s)
GSV-3USBx2 2mV/V	2 channels, 2x Input $\pm 2$ mV/V, 2x M12 socket
GSV-3USBx2 2mV/V 10V	2 channels, Port "A" strainage sensor, Port "B" $\pm 10$ V input, 2x M12 socket
GSV-3USBx2 2mV/V 4,2V	2 channels, Port "A" strainage sensor, Port "B" potentiometric sensor, 2x M12 socket
GSV-3USBx2 2mV/V RPM	2 channels, Port "A" strainage sensor, Port "B" pulse generator with direction, 2x M12 socket
GSV-3USBx2 2mV/V RPM/SubD15	2 channels, Port "A" strainage sensor, Port "B" pulse generator with direction, 1x SubD15

*Other models available on request;*