

TS170 ±50Nm



Description

The torque sensor comprises an external flange and an inner flange, which are inter-connected via 4 torque axle brackets. The outer and inner flange have 6 or 4 M8 screw threads respectively to apply torque.

The sensor is designed to measure the reaction torque. For this purpose, the engine is constrained exclusively by the sensor. The structure with internal holes is selected to ensure that engine or test bench shafts have sufficient space.

The torque sensor TS170 is used in torque testers for quality assurance as well as in manufacturing machines.

Dimensions

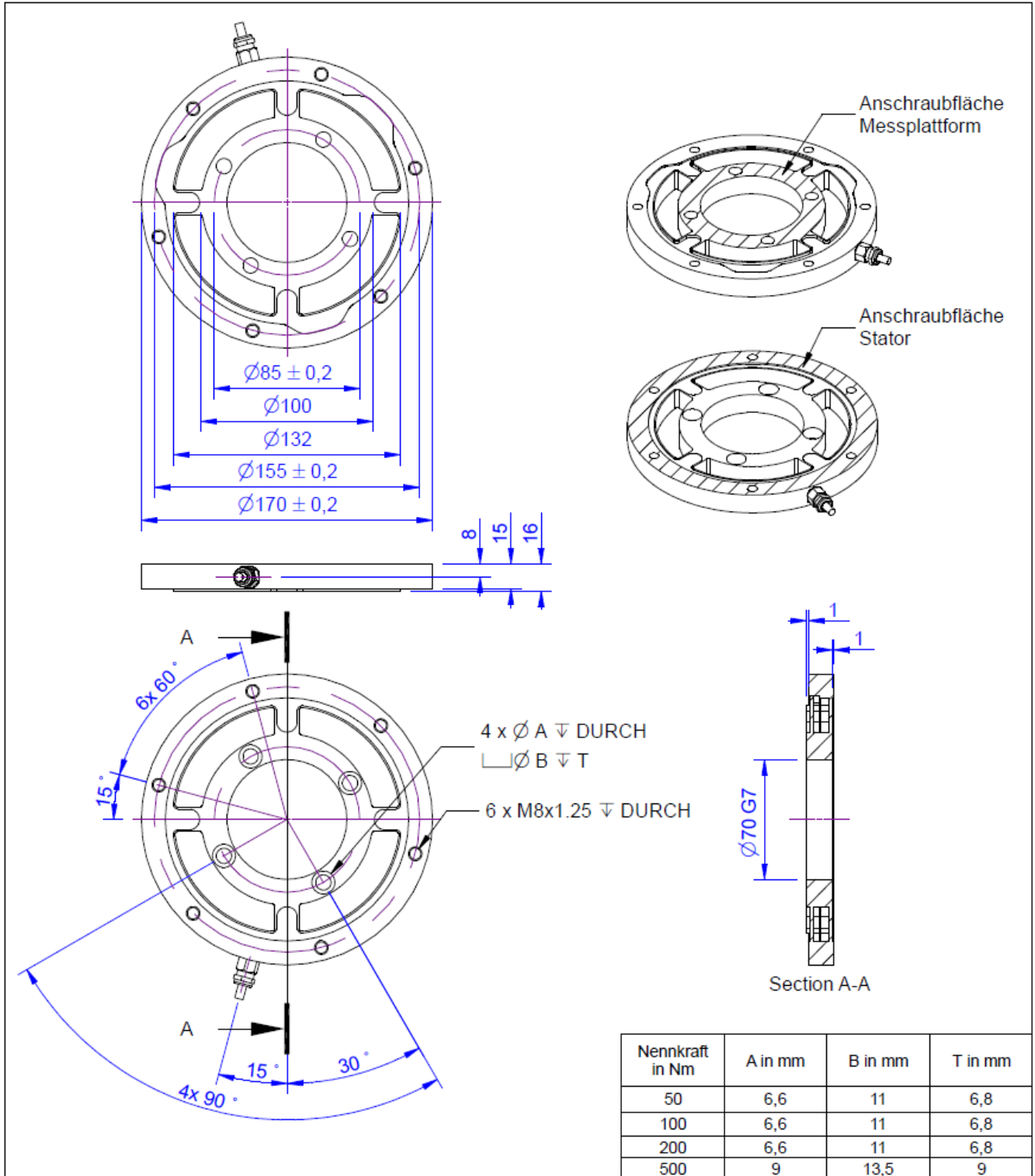

Technical Data

Electrical Data

Input resistance	700 Ohm
Tolerance input resistance	10 ±
Output resistance	700 Ohm
Tolerance output resistance	10 ±
Insulation resistance	5x10 ⁹ Ohm
Rated range of excitation voltage f	2.5 ... 5 V
Operating range of excitation voltage f	1 ... 10 V
Zero signal	0.05 mV/V
Rated output	1 mV/V / FS

Precision

Accuracy class	0,1%
Relative linearity error	0.1 %FS
Relative zero signal hysteresis	0.1 %FS
Temperature effect on zero signal	0.1 %FS/K
Temperature effect on characteristic value	0.1 %RD/K
Relative creep	0.05 %FS

Connection Data

Name of the connection	ME-SYSTEME.DE / 24-4 PUR
Cable length	5 m

Temperature

Rated temperature range f	-20 ... 60 °C
Operating temperature range f	-20 ... 70 °C
Storage temperature range f	-20 ... 70 °C
Environmental protection	IP65

Basis Data

Type	shear beam
Rated torque	50 Nm
Bending moment limit	50 Nm
Maximum operating torque	150 %FS
Breaking torque	400 %FS
Rated torsion angle	0.03 °/FS
Axial force limit	1000 N
Lateral force limit	1000 N
Torque introduction	pitch circle
Dimension 1	Ø85
drehmomentausleitung	pitch circle
Dimension 2	Ø155
Diameter	170 mm
length	16 mm



Material

Aluminium alloy

Abbreviation: RD: „Reading“; FS: „Full Scale“;

1) The exact nominal sensitivity is indicated in the test report;





Pin Configuration

Symbol	Description	Wire colour
+Us	positive bridge supply	brown
-Us	negative bridge supply	white
+Ud	positive bridge output	green
-Ud	negative bridge output	yellow

Screen - transparent.

Compressive load : positive output signal

accessories

Description	Description
	Factory calibration certificate Nm/50/5 Detection of the characteristic value and traceability on DAkkS torque device; 0.025Nm... 50Nm
	Factory calibration certificate Nm/50/5/System Detection of the characteristic value and traceability on DAkkS torque device; 0.025Nm... 50Nm; incl. calibration, torque sensor + amplifier