

## KS180 15kN/97



### Description

The KS180 force sensor is suitable for measuring forces between two bearing surfaces.

For example, this force sensor is used to measure the bearing force of pedestal bearings. The dimensions of the force sensor match the standard "LASE" pedestal bearing housing units by INA.

Other dimensions can be produced on request according to designs.

## Dimensions

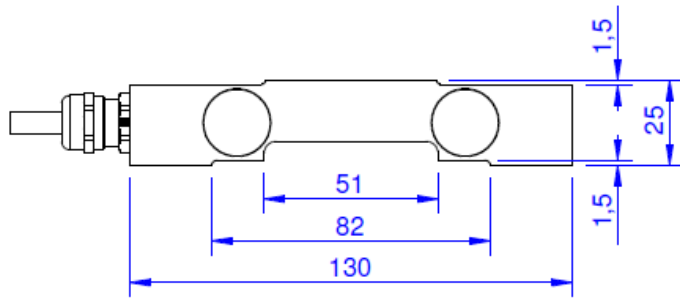

Anschraubfläche  
Messplattform

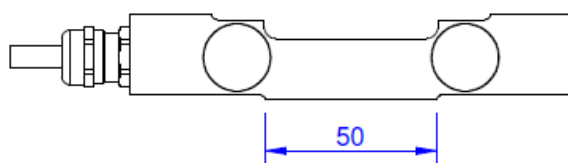
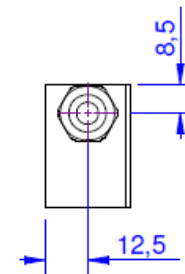
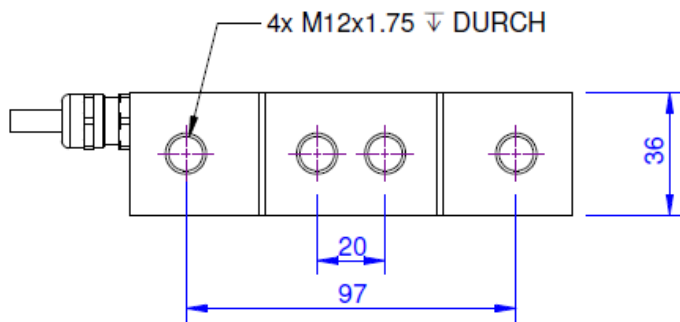
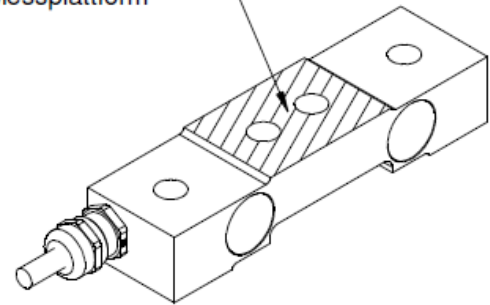

Anschraubflächen  
Stator

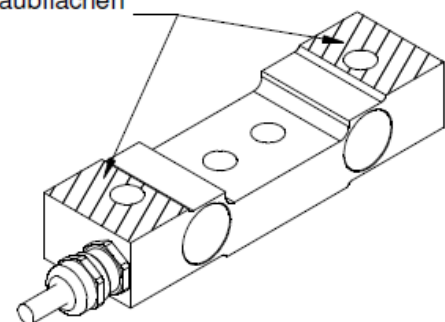

## Technical Data

### Force sensor

Type	Force sensor
Force direction	Tension / Compression
Rated force F <sub>x</sub>	15 kN
Force introduction	Inner thread
Dimension 1	2xM12x1,75
Sensor Fastening	Inner thread
Dimension 2	2xM12x1,75
Operating force	150 %FS
Rated displacement	0.1 mm
Lateral force limit	8 kN
Surface	electrogalvanized
Height	25 mm
Length or Diameter	130 mm
Bending moment limit	100 Nm

### Electrical Data

Input resistance	390 Ohm
Tolerance input resistance	40 Ohm
Output resistance	350 Ohm
Insulation resistance	2 GOhm
Rated range of excitation voltage f	2.5 ... 5 V
Operating range of excitation voltage f	1 ... 10 V
Zero signal	0.05 mV/V
Rated output	1 mV/V / FS

### Precision

Accuracy class	0,5%
Relative linearity error	0.1 %FS
Relative zero signal hysteresis	0.1 %FS
Temperature effect on zero signal	0.01 %FS/K
Temperature effect on characteristic value	0.02 %RD/K
Relative creep	0.1 %FS

### Connection Data

Connection type	4 conductor open
Name of the connection	2x2x0,25/PUR
Cable length	5 m

### Temperature

Rated temperature range f	-10 ... 70 °C
Operating temperature range f	-10 ... 85 °C
Storage temperature range f	-10 ... 85 °C
Environmental protection	IP65



*Abbreviation : RD: „Reading“; FS: „Full Scale“;*

*1) The exact nominal sensitivity is indicated in the test report.*







## Pin Configuration

Symbol	Description	Wire colour
+Us	positive bridge supply	brown
-Us	negative bridge supply	white
+Ud	positive bridge output	green
-Ud	negative bridge output	yellow

Screen - transparent.

Pressure load: positive output signal

## accessories

	Description	Description
	Calibration Certificate kn/20/5	Factory calibration certificate for force to 20 kN in accordance with DIN EN ISO / IEC 17025 for test materials monitoring according to DIN ISO 9001: 2008 with 5 load levels and 3 series of measurements.
	GSV-1H	Measuring amplifier in top-hat rail housing for sensors with strain gauges. Analogue output -10V...+10V, limiting frequency 250Hz, 4 input sensitivities from 2.0mV/V.
	GSV-2TSD-DI	Measuring amplifier in desktop-housing for sensors with strain gauges. Serial port RS232, USB port, analogue output -5V...+5V, limiting frequency 260Hz, input sensitivity 3.5mV/V.
	GSV-3USB	Measuring amplifier in aluminum housing for sensors with strain gauges. Limiting frequency 1250Hz, input sensitivity 2 / 3,5 / 10 mV/V.
	GSV-6K	Analogue measuring amplifier in plug housing for sensors with strain gauges. Analogue output configurable, TEDS, sampling frequency 1Hz ... 25kHz, input sensitivity configurable 0.1mV/V ... 8mV/V