

GSV-3BT M12



Highlights

- supply voltage 3,0...5,5 Volt
- Bluetooth®
- integrated bridge completion for 350 Ohm
- data rate 1...1000/s

Description

The measuring amplifier GSV-3BT supports wireless data acquisition with strain gauge-sensors.

The GSV-3BT can be used for the connection of Strain-gage-fullbridges and halfbridges. For quarterbridges 350 Ohm there is a possibility for connection in three-wire technique.

The data transmission is via Bluetooth Standard 2.0+EDR with Serial Port Profile (SPP). The range is up to 20m in buildings and up to 100m with visual connection. For a receiver a commercial Bluetooth-Dongle with Widcom- or Toshiba driver unit which supports the „serial-port-protocol“ can be used.

Data acquisition occurs through the Software GSV Control. Possible data rates are from 1/s up to 1000/s. The internal sampling rate of GSV-3BT is 10000/s.

For the alimentation a Lithium-Polymer-akku may be used.

The electric power consumption is less than 100mA. In the passive state the electric power consumption is below 1 mA.

Dimensions

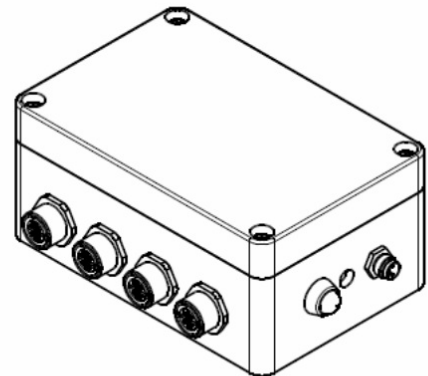
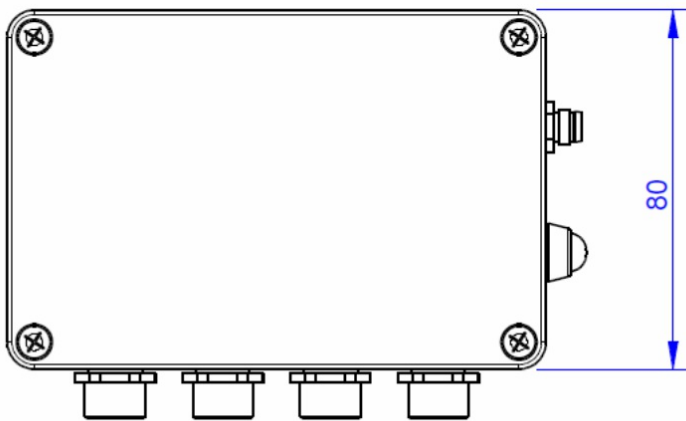
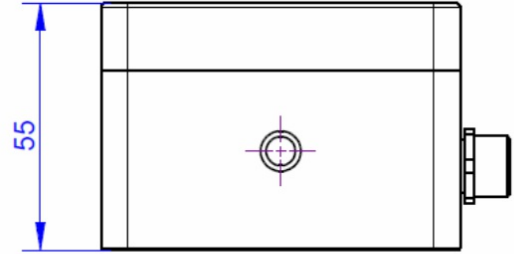
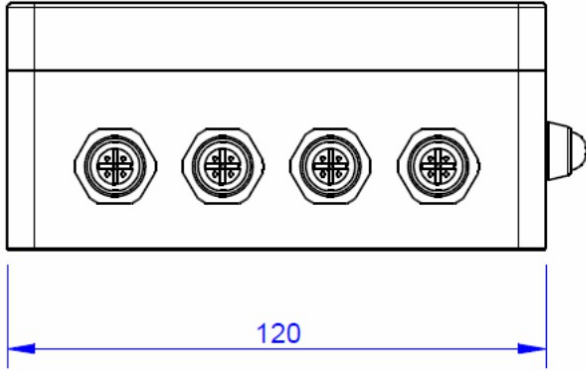

Technical Data

Basis Data

Housing	Grouting
Connection	Connector
Number of channels	1-Kanal

Input analog

Number of analog inputs	1
Input sensitivity-steps	2.0 mV/V
Input resistance strain-gauge-full-/half-bridge	350 ... 5000 Ohm

Precision

Accuracy class	0,1%
Relative linearity error	0.02 %FS
Temperature effect on the zero point	0.01 %FS/10°C
Temperature effect on the measuring sensitivity	0.01 %RD/10°C
Resolution	16 Bit

Supply

Supply voltage f	9 ... 37 V
Current consumption from	100 mA
Strain gauge bridge supply	2.5 V

Interface

Type of the interface	bluetooth
Quantity of the interface	1
Version of the interface	Bluetooth 2.0+EDR

Temperature

Rated temperature range f	-10 ... 65 °C
Operating temperature range f	-40 ... 85 °C
Environmental protection	IP66

Measuring frequency

Data frequency to	1000 Hz
-------------------	---------

Mounting

Measurement resolution

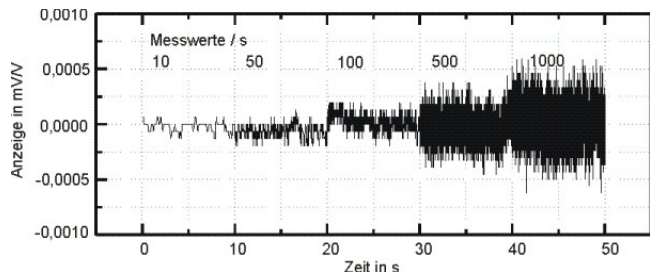

The achievable signal/noise ratio depends on the ambient conditions (cable length, shielding), on the selected data rate, and on the optionally connected FIR filtering. The graphic shows the resolution with 1m connecting cable, measuring range $\pm 2\text{mV/V}$, FIR filter switched off.

Connector pin assignment

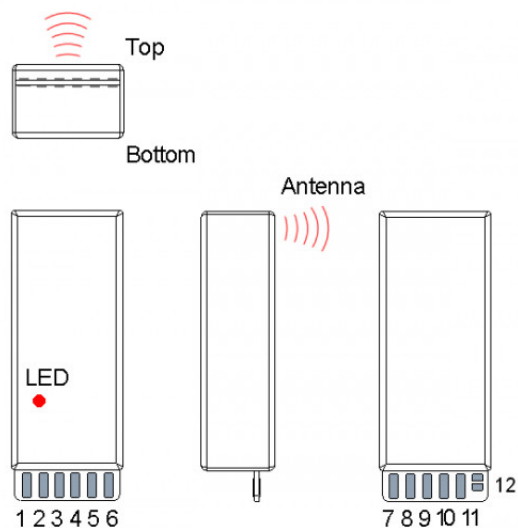

Note: The antenna may not be shielded by conductive materials or liquids. The status LED indicates whether a Bluetooth connection exists.

Connectors on the upper side of the circuit board

Pin 1	Pin 2	Pin 3	Pin 4	Pin 5	Pin 6
-Us - Bridge excitation	+Us + Bridge excitation	+Ud + Bridge -input	-Ud - Bridge -input	Us +3,0...+5,5V	GND Ground

Connectors on the lower side of the circuit board



Pin 7	Pin 8	Pin 9	Pin 10	Pin 11	Jumper 12
GND Ground	internally assigned	T Zero-setting input / Trigger input	S1 Threshold generator Output	Aux Connection for Quarter bridge	Half bridge completion

Wiring diagram for quarter and half bridges to GSV-3BT

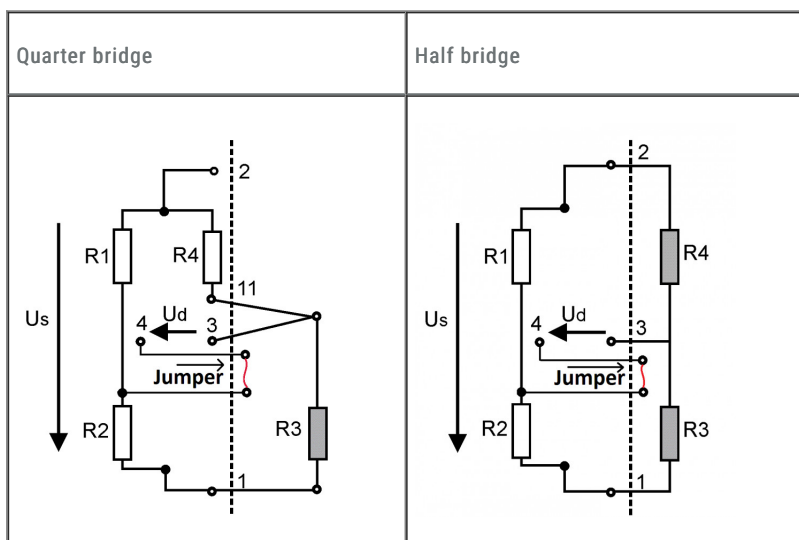

Table 1: Wiring diagram for quarter and half bridges to GSV-3BT

The DMS full bridge is connected to the pins 1, 2, 3, 4 (jumper open), the half bridge to the pins 1, 2, 3 (jumper closed) and the quarter bridge to the pins 1, 3, 11 (jumper closed).

The calibration of the measuring amplifier is valid for a full bridge with 350 ohm. The internal supplement resistors R1 and R2 are 10 ohm and R4 is 350 ohm.

Connecting the rpm generator to the GSV-3BT RS

Using the hall switch HAL501 and a permanent magnet, a rpm measurement of 5 ... 15mm can be realised via an air gap.

Prerequisite for the detection of a pulse for the rpm measurement is a change of the magnetic flux density from 20mT to 4mT.

Depending on configuration, the measuring amplifier GSV-3BT RS transmits either

- the torque M or the strain gauge's output signal,
- the rpm n in rotations per minute,
- the power [P] = watt; [M] = Nm;

The measuring value is either transmitted

- with the set measuring frequency,
- at each magnetic impulse.

If the data transmission is triggered by magnetic pulse, the torque can then be transmitted, and the rotational power can be calculated on the stator side from the number of measuring values per unit of time.

The measurement amplifier is configured to power measurement by selecting the unit W (watt) in the configuration program. In doing so it should be noted that the sensitivity of the strain gauge input has been set in Nm. The number of magnets on the rpm input also has to be set correctly.

The measuring amplifier is configured to the rpm measurement by selecting the unit rpm. The measured values are always transmitted in text format for GSV-3BT RS. The scaling of the rpm input is fixed at 20000 and cannot be changed. The number of magnets that generate pulses at the hall sensor can be set using gsvterm.exe. For this purpose, the menu item 'Special settings' is on page 2 of the programming interface.

A maximum of 100 measured values/s are transmitted, the internal sampling frequency is 6000/s.

Hall switch HAL501	Cable, colour	GSV-3BT RS	Description
1	white	8	Vdd (5V, <5mA)
2	brown	7	GND
3	green	11	Signal (TTL-Level)

Instead of the Hall switch HAL501, other sensors with an input power of less than 5V, 5mA and an output signal at TTL level can be connected.

Using a NdFeB 20mmx10mmx4mm bar magnet, a working distance of at least 10mm between the Hall switch and magnet is achieved.

Number of magnets	Range of speeds in rotations/min		Response time in number of rotations	
	Minimum	Maximum	Minimum	Maximum
1	18	36000	ca. 1	ca. 2
2	9	18000	ca. 1/2	ca. 1
4	4,5	9000	ca. 1/4	ca. 1/2
8	2,25	4500	ca. 1/8	ca. 1/4



Figure 3: Hall switch HAL501 in T092 housing, view from above on sensitive surface (facing the magnetic south pole)

Connecting asymmetrical full bridges to GSV-3BT

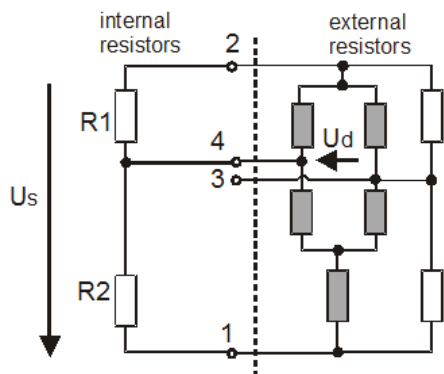

Figure 4: Wiring diagram for GSV-3BT QB for asymmetrical full bridges

Strain gauge full bridges are partially supplemented asymmetrically with series resistors to balance the output signal and compensate for the temperature drift. The R1 and R2 resistors of the GSV-3BT QB supplemental circuit then cause an offset that in extreme cases can no longer be adjusted. In this case, the centre tap of an additional 10 kOhm voltage divider must be connected to + Ud (terminal 3).

Connector pin assignment for external supply voltage M8, 4-pin

An external voltage supply can be connected via the 4-pin M8 round plug connector.

Pin	Function	Sensor-actuator cable M8
1	Supply voltage 9...28 V DC	brown
2	Battery 4,2V	white
3	GND supply voltage	blue
4	Battery GND	black

Connector pin assignment for M12 round plug connector, 5-pin

Assignment for the DMS sensors

	Description (DMS)	Pin-Nr	Sensor-actuator-cable
+U _S	positive bridge excitation	1	brown
-U _S	negative bridge excitation	2	white
+U _D	positive bridge output	3	blue
-U _D	negative bridge output	4	black
AUX	Quarter bridge- /voltage-input, potentiometric input	5	gray

Switch configuration GSV-3BT M12





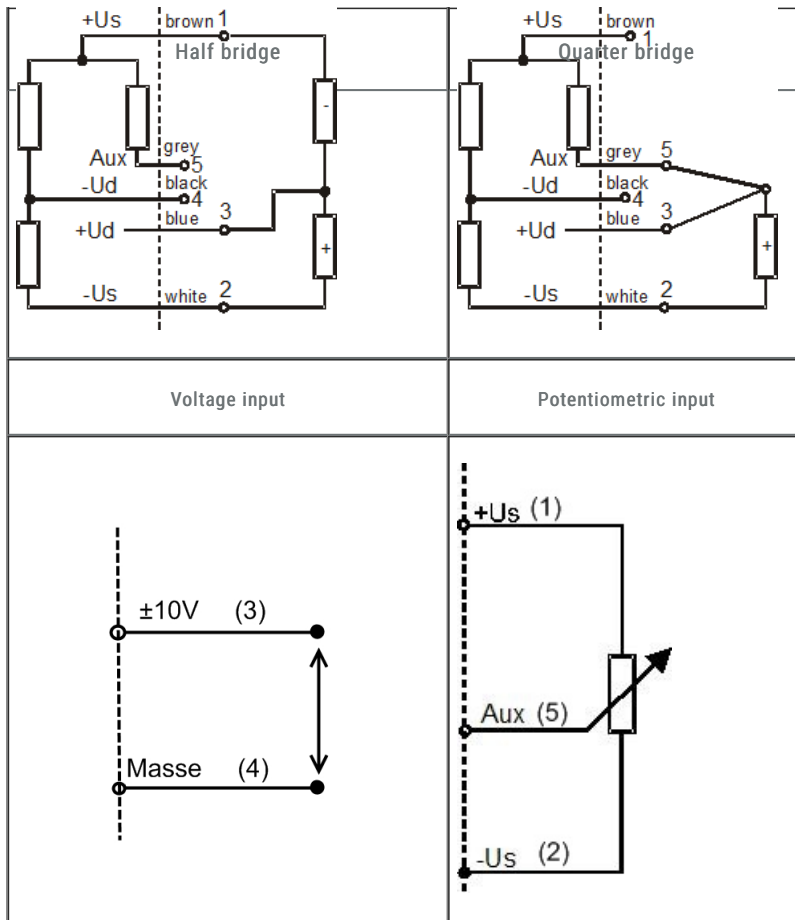

Eingang	Links								Rechts							
	1 braun	2 rot	3 orange	4 gelb	5 grün	6 blau	7 lila	8 grau	9 braun	10 rot	11 orange	12 gelb	13 grün	14 blau	15 lila	16 grau
Vollbrücke	OFF	ON	OFF	OFF	OFF	OFF	ON	OFF	OFF	OFF	OFF	OFF	OFF	OFF	OFF	ON
Halbbrücke	OFF	ON	OFF	OFF	OFF	OFF	ON	OFF	OFF	OFF	OFF	OFF	OFF	OFF	OFF	ON
Viertelbrücke 120 Ohm	OFF	ON	OFF	OFF	OFF	OFF	ON	OFF	OFF	ON	OFF	OFF	OFF	OFF	OFF	ON
Viertelbrücke 350 Ohm	OFF	ON	OFF	OFF	OFF	OFF	ON	OFF	OFF	OFF	ON	OFF	OFF	OFF	OFF	ON
Viertelbrücke 1000 Ohm	OFF	ON	OFF	OFF	OFF	OFF	ON	OFF	OFF	OFF	OFF	ON	OFF	OFF	OFF	ON
potentiometrischer Wegsensor	ON	OFF	OFF	ON	ON	ON	OFF	OFF	ON	OFF	OFF	OFF	OFF	ON	OFF	ON
Spannung	ON	OFF	ON	OFF	ON	ON	OFF	OFF	OFF	OFF	OFF	OFF	OFF	ON	OFF	OFF

Wiring diagram for GSV-3BT M12

Half bridge	Quarter bridge



accessories

	Description	Description
	Bluetooth USB-Dongle UD100	Bluetooth USB-Dongle for extended range
	Charger M8	2m Connecting cable 4x0,25/PVC, with M8-round plug (female), 4-pole, Series 718
	Charger Ultramat 14 plus	Charging sockets 4mm, Power supply 230VAC or 12V DC, 1-14 NiMh cells, 1-5 Li-ion cells, 1-5 Li-Po cells, 1-6 Pb cells, charging current 0.1A-5A, Trickle Charge, Dimensions : 148mm x 146mm x 54mm
	Connector xp/m/M12/0	Cable plug connector, 4 / 5 poles, shieldable



Orderoptions

Type	Description
GSV-3BT SD	miniature version, solder connection
GSV-3BT RS	miniature version, solder connection, power measurement
GSV-3BT M12	housed version with battery and