

Force Sensor KM38 0,5kN/M4

Item number: 10595



The miniature force sensor KM38 M4 is exceptionally suitable for measuring preload of bolts on account of its flat construction and its through hole.

But the inner thread M4x0.7 is also suitable for introduction of a force transmission. With a spherical cap the force transmission can be centered and made free of lateral force .

Through the introduction of half liners or prisms these force sensors can be adapted to the measurement of rolling forces.

The three M2.5 thread holes on the bottom side permit the attachment of the sensor or the fitting of a prism.

Technical Drawing

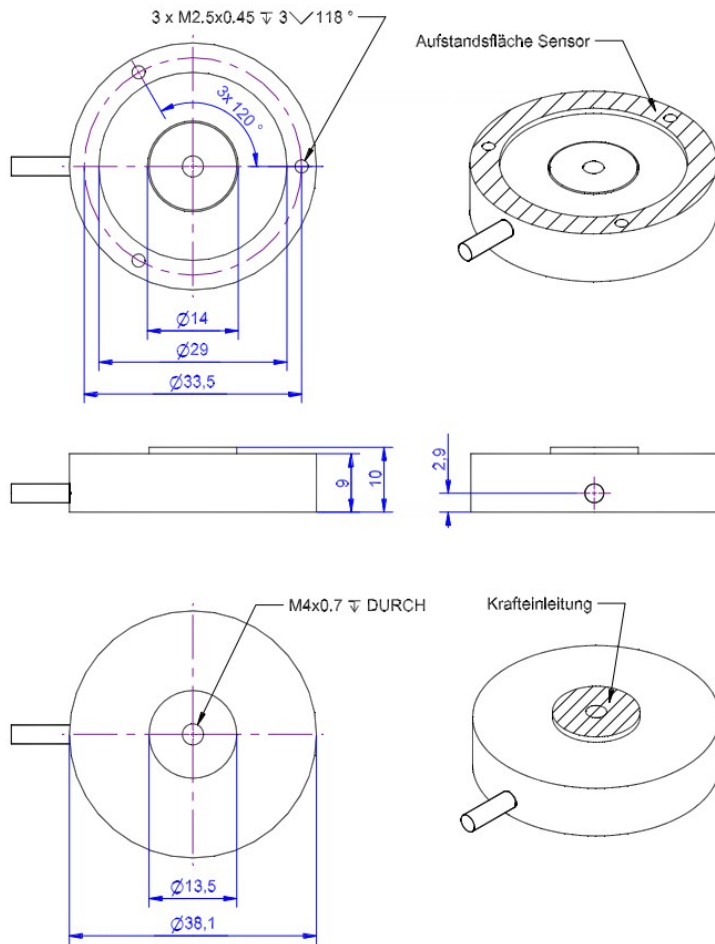

Technical Data

Basic Data		Unit
Type	Force load cell	
Force direction	Compression	
Rated force Fx	0.5	kN
Force introduction	Internal thread	
Dimension 1	M4x0.7	
Sensor Fastening	Circular ring	
Dimension 2	Ø38x4,5	
Operating force	150	%FS
Rated displacement	0.06	mm
Lateral force limit	50	%FS
Material	Stainless steel	
Natural frequency fx	5	kHz
Dimensions	Ø38 mm x 10 mm	
Height	10	mm
Length or Diameter	38	mm
Torque limit	5	Nm
Bending moment limit	5	Nm
Variants	1KN ... 20KN	

Electrical Data		Unit
Input resistance	780	Ohm
Tolerance input resistance	80	±
Output resistance	703	Ohm
Tolerance output resistance	5	±
Insulation resistance	2x10 ⁹	Ohm
Rated range of excitation voltage from	2.5	V
Rated range of excitation voltage to	5	V
Operating range of excitation voltage from	1	V
Operating range of excitation voltage to	10	V
Zero signal	0.05	mV/V
Rated output	1	mV/V / FS

Accuracy Data		Unit
Accuracy class	1	
Relative linearity error	0.1	%FS
Relative zero signal hysteresis	0.05	%FS
Temperature effect on zero signal	0.02	%FS/K
Temperature effect on characteristic value	0.02	%RD/K
Relative creep	0.1	%FS

Environmental Data		Unit
Rated temperature range from	-10	°C
Rated temperature range to	70	°C
Operating temperature range from	-10	°C
Operating temperature range to	85	°C
Storage temperature range from	-10	°C
Storage temperature range to	85	°C
Environmental protection	IP66	

Abbreviation: RD: „Reading“; FS: „Full Scale“;1) The exact nominal sensitivity is indicated in the test report;

Pin Assignment

Channel	Symbol	Description	Wire color	PIN
	+Us	positive bridge supply	red	
	-Us	negative bridge supply	black	
	+Ud	positive bridge output	green	
	-Ud	negative bridge output	white	

Pressure load: positive output signal.Shield- transparent.