

6-Axis Force Sensor F6D45 20N/1Nm/CG

Item number: 11324



Highlights

- smallest forces F_x , F_y : 20 N, F_z : 50 N
- and torque M_x , M_y , M_z : 1 Nm
- light-weight construction
- integrated overload protection
- robust connection cable

The multi-component sensor F6D45 is used for force and torque measurement in three mutually perpendicular axes.

The multi-component sensor F6D45 is equipped with fastening flanges according to DIN EN ISO 9409-1 for industrial robots. The measuring flange of the sensor contains tapped holes M3 on the same pitch circle. The F6D force / torque sensor can be mounted to the robot flange without additional adapters, making it particularly flat and light compared to the K6D series sensors.

The 24-signal line is divided into two cables with 12 wires each.

The evaluation of the force and moment load is carried out with an external measuring amplifier GSV-8DS SubD44HD or GSV-8AS.

The sensors are made of an aluminum alloy.

Our robotics partner IPR offers solutions for applications of force / torque sensors.

Technical Drawing

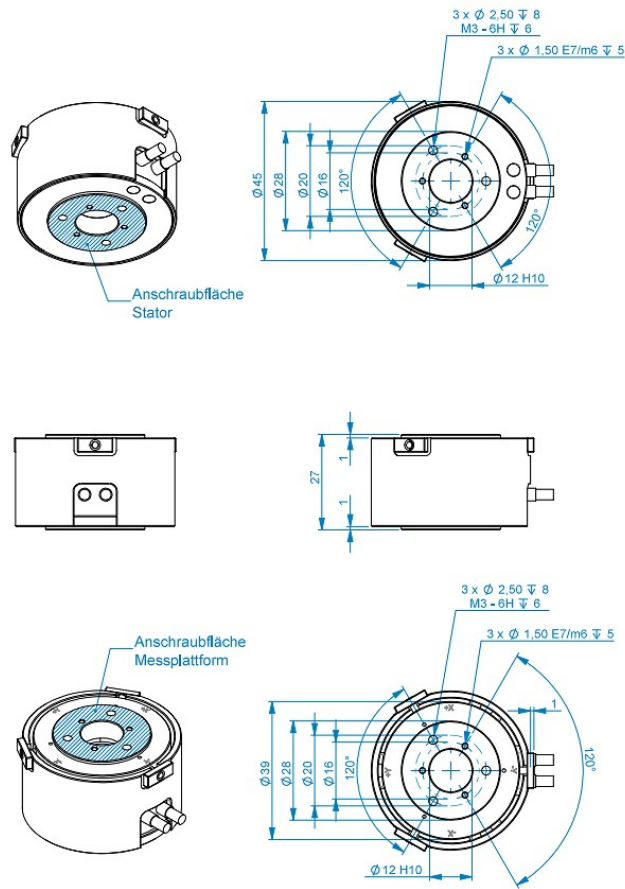

Technical Data

| Basic Data | | | Unit |
|----------------------|---------------------|--|------|
| Type | 6-axis force sensor | | |
| Force direction | Tension/Compression | | |
| Rated force Fx | 20 | | N |
| Rated force Fy | 20 | | N |
| Rated force Fz | 50 | | N |
| Force introduction | Internal thread | | |
| Dimension 1 | 3xM3 | | |
| Sensor Fastening | Internal thread | | |
| Operating force | 300 | | %FS |
| Rated displacement | 0.05 | | mm |
| Twist | 0.04 | | rad |
| Material | aluminum-alloy | | |
| Height | 27 | | mm |
| Length or Diameter | 45 | | mm |
| Rated torque Mx | 1 | | Nm |
| Rated torque My | 1 | | Nm |
| Rated torque Mz | 1 | | Nm |
| Torque limit | 150 | | %FS |
| Bending moment limit | 150 | | %FS |
| Breaking force | 600 | | %FS |

| Electrical Data | | Unit |
|--|------|------|
| Input resistance | 100 | Ohm |
| Tolerance input resistance | 50 | Ohm |
| Output resistance | 1000 | Ohm |
| Tolerance output resistance | 50 | Ohm |
| Insulation resistance | 2 | GOhm |
| Rated range of excitation voltage from | 2.5 | V |
| Rated range of excitation voltage to | 5 | V |
| Operating range of excitation voltage from | 1 | V |
| Operating range of excitation voltage to | 10 | V |
| Zero signal | 1 | mV/V |
| Characteristic value range from | 0.5 | mV/V |
| Characteristic value range to | 1.5 | mV/V |

| Eccentricity and Crosstalk | | Unit |
|----------------------------|--|------|
|----------------------------|--|------|

| Accuracy Data | | Unit |
|--|------|-------|
| Accuracy class | 1 | |
| Relative linearity error | 0.1 | %FS |
| Relative zero signal hysteresis | 0.1 | %FS |
| Temperature effect on zero signal | 0.1 | %FS/K |
| Temperature effect on characteristic value | 0.05 | %RD/K |
| Relative creep | 0.1 | %FS |
| Relative repeatability error | 0.5 | %FS |

| Environmental Data | | Unit |
|----------------------------------|------|------|
| Rated temperature range from | -10 | °C |
| Rated temperature range to | 70 | °C |
| Operating temperature range from | -10 | °C |
| Operating temperature range to | 85 | °C |
| Storage temperature range from | -10 | °C |
| Storage temperature range to | 85 | °C |
| Environmental protection | IP64 | |

Abbreviation : RD: „Reading“; FS: „Full Scale“; The application of a calibration matrix is required for the determination of the forces F_x , F_y , F_z and moments M_x , M_y , and M_z from the 6 measurement channels, and to compensate for the crosstalk.

The calibration data are individually determined and documented for the sensor.

The measurement error is expressed individually by the specification of the extended measurement uncertainty ($k = 2$) for the forces F_x , F_y , F_z , and moments M_x , M_y , M_z .

Mounting

Calibration matrix

The calibration matrix contains 36 calibration factors for calculating the forces and torques from the 6 output signals of the force sensor. A Labview vi is available for processing the calibration matrix

Measuring amplifier

The measuring amplifier GSV-8DS or GSV-8AS has 24-pole plug connector to connect the 6-axis force/torque sensor. The mechanical forces and torques are calculated from 6 output voltages of each measuring channel with the calibration matrix.

Software

The GSVmulti software is included in delivery with measuring amplifiers GSV-8. The software allows the application of the calibration matrix and the displacement of the coordinate system to represent the torques around a freely selectable reference point.

To create your own software, a Labview VI is available.

Mounting instruction

The force is applied to a circular ring ($\varnothing 80$ - $\varnothing 40$) on the live end of the sensor. The area inside the circular ring remains unloaded.

3 centering hole $\varnothing 1,5$ serves to secure the angular position.

3x M3 internal thread for mounting the tool (this flange corresponds again to the robot flange);

Robotics solutions from IPR

Our robotics partner IPR offers solutions for applications of force / torque sensors in the areas of

- Mounting and handling technology
- Machine loading
- Foundry and blacksmith
- Cavity preservation
- Sealing and damping
- Lack and paint
- Services

IPR - Intelligente Peripherien für Roboter GmbH

Industriestraße 29
74193 Schwaigern
Deutschland

Tel: +49 7138 812-100

email: info@iprworldwide.com

Stiffness Matrix

| | | | | | |
|--|--|--|--|--|--|
| | | | | | |
|--|--|--|--|--|--|