

6-Axis Force Sensor K6D175 10kN/1kNm/UP13

Item number: 10099



The K6D175 multi-component sensor enables force and torque measurement in three mutually perpendicular axes. The K6D175 multi-component sensor features a wide measuring range for forces and moments. This multi-component sensor uses a "Stewart platform"-shaped rod assembly that absorbs the forces and moments directly on the pitch circle of the mounting threads. This achieves maximum rigidity and the largest possible measuring range for torques. The force is applied to the 1.7 mm raised segments. The 120H8 inner diameter of the segments serves as centering. The segmented, annular end face ensures optimal force application and thus the best possible reproducibility on the order of approximately 0.2%.

Crosstalk (particularly from the force component F_x to the force component F_y , as well as the systematic deviation in the force component F_y) can be up to 8% FS in the 50 kN/5 kNm version. In the 20 kN/2 kNm version, this effect is approximately 4% FS, and in the 10 kN/1 kNm version, this effect is approximately 2% FS.

With the **K6D175a** versions, this systematic error is eliminated by providing a total of 12 measurement channels for compensation (6x12 matrix).

The multi-component force sensor is ideally suited for applications in robotics, such as:

- Collision detection
- Teach-in
- Presence or error detection
- Force or torque-controlled operation
- Load measurement in medical technology / prosthetics / orthopedic technology / gait analysis
- Measurements in sports medicine
- Comfort measurements / ergonomic measurements

The evaluation of the force and torque load is carried out, for example, with a GSV-8DS measuring amplifier.

The K6D175 sensors are made of high-strength stainless steel 1.4542.



Technical Drawing

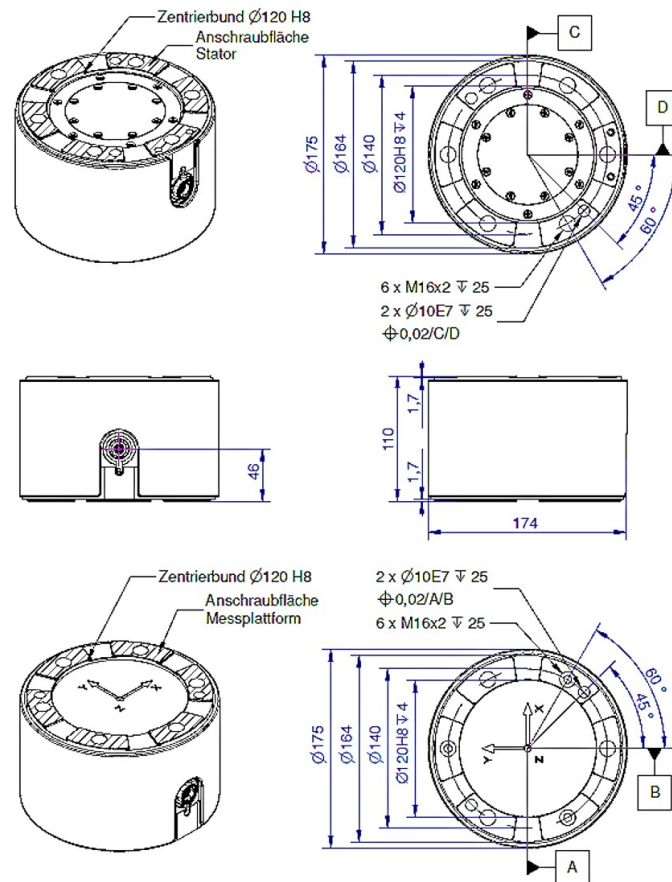

Technical Data

Basic Data		Unit
Type	6-axis force sensor	
Force direction	Tension/Compression	
Rated force Fx	10	kN
Rated force Fy	10	kN
Rated force Fz	20	kN
Force introduction	Innengewinde	
Dimension 1	6x M16x2	
Sensor Fastening	Internal thread	
Dimension 2	6x M16x2	
Operating force	200	%FS
Rated displacement	0.1	mm
Twist	0.01	rad
Material	Stainless steel	
Natural frequency fx	1.2	kHz
Height	110	mm
Length or Diameter	175	mm
Rated torque Mx	1	kNm
Rated torque My	1	kNm
Rated torque Mz	1	kNm
Torque limit	300	%FS
Bending moment limit	300	%FS

Electrical Data		Unit
Input resistance	350	Ohm
Tolerance input resistance	10	Ohm
Output resistance	350	Ohm
Tolerance output resistance	10	Ohm
Insulation resistance	2	GOhm
Rated range of excitation voltage from	2.5	V
Rated range of excitation voltage to	5	V
Operating range of excitation voltage from	1	V
Operating range of excitation voltage to	10	V
Zero signal from	-0.05	mV/V
Zero signal to	0.05	mV/V
Characteristic value range from	0.45	mV/V
Characteristic value range to	0.7	mV/V

Eccentricity and Crosstalk		Unit
Crosstalk from x to y at rated load	2	%FS
Crosstalk	1	%FS

Accuracy Data		Unit
Accuracy class	0,5	
Relative linearity error	0.1	%FS
Relative zero signal hysteresis	0.1	%FS
Temperature effect on zero signal	0.1	%FS/K
Temperature effect on characteristic value	0.05	%RD/K
Relative creep	0.1	%FS
Relative repeatability error	0.5	%FS

Environmental Data		Unit
Rated temperature range from	-10	°C
Rated temperature range to	70	°C
Operating temperature range from	-10	°C
Operating temperature range to	85	°C
Storage temperature range from	-10	°C
Storage temperature range to	85	°C
Environmental protection	IP65	

Abbreviation : RD: „Reading“; FS: „Full Scale“; The application of a calibration matrix is required for the determination of the forces F_x , F_y , F_z and moments M_x , M_y , and M_z from the 6 measurement channels, and to compensate for the crosstalk.

The calibration data are individually determined and documented for the sensor.

The measurement error is expressed individually by the specification of the extended measurement uncertainty ($k = 2$) for the forces F_x , F_y , F_z , and moments M_x , M_y , M_z .

PIN Assignment

Channel	Symbol	Designation	Color	PIN
1	+Us	positive bridge supply	green	4
	-Us	negative bridge supply	yellow	3
	+Ud	positive bridge output	white	9
	-Ud	negative bridge output	brown	8
2	+Us	positive bridge supply	blue	10
	-Us	negative bridge supply	red	11
	+Ud	positive bridge output	gray	2
	-Ud	negative bridge output	pink	1
3	+Us	positive bridge supply	gray-pink	6
	-Us	negative bridge supply	red-blue	5
	+Ud	positive bridge output	black	12
	-Ud	negative bridge output	purple	7
4	+Us	positive bridge supply	white-yellow	23
	-Us	negative bridge supply	yellow-brown	18
	+Ud	positive bridge output	white-green	21
	-Ud	negative bridge output	brown-green	22
5	+Us	positive bridge supply	white-pink	15
	-Us	negative bridge supply	brown-pink	14
	+Ud	positive bridge output	white-gray	17
	-Ud	negative bridge output	gray-brown	16
6	+Us	positive bridge supply	white-red	20
	-Us	negative bridge supply	brown-red	24
	+Ud	positive bridge output	white-blue	13
	-Ud	negative bridge output	brown-blue	19
-	shield		transparent	

Shield: connected with sensor housing;

Mounting

The force is applied to an annulus/to 6 segments of a circle, 155 mm – 140 mm in diameter, on the end faces of the sensor. No force is applied to the area inside the 140 mm in diameter ring.

The areas outside the annuli can be used for centring purposes. A centring hole is provided to secure the angular position.

Recommended tightening torque: 250Nm.

Stiffness Matrix

178.1 kN/mm	0.0	0.0	0.0	10331 kN	0.0
0.0	178.1 kN/mm	0.0	-103314 kN	0,0	0.0
0.0	0.0	786.7 kN/mm	0.0	0,0	0.0
0.0	-10331 kN	0.0	2149.7 kNm	0,0	0.0
10331 kN	0.0	0.0	0.0	2149.7 kNm	0.0
0.0	0.0	0.0	0.0	0.0	1404.3 kNm

- The elements with the unit kN/mm describe the relationship between force and path.
- The elements with the unit kNm describe the relationship between torque and twist.
- The elements with the unit kN describe the relationship between torque and path (columns 1 to 3) or the relationship between force and twist (columns 4 to 6)