

6-Axis Force Sensor K6D150 2kN/200Nm/MP11

Item number: 10095



The multi-component sensor K6D150 allows force and torque measurement in three mutually perpendicular axes.

The multi-component sensor K6D150 is characterized by a big measuring range for forces and torques.

With this multi-component sensor of the „second generation“ is used rod construction, which absorbs forces and torques directly on the pitch circle of the fastening thread. The force transmission is applied on the 1 mm raised segments. The inner diameter of segments is used for the centering. Due to segmented, ring-shaped front surface, the optimal force transmission and therefore the best possible reproducibility in the range of about 0,1 % will be obtained.

The multi-component force sensor is very well suited for use in robotics, e.g.

- For collision detection
- "Teach-In"
- Collision detection
- Force or torque-controlled operation
- Load measurement in medicine, prosthetics, orthopaedic engineering
- Measurement in sports medicine
- Comfort / ergonomics measurements

The force and torque loadings are evaluated e.g. using a GSV-8DS measurement amplifier. The sensor K6D150 2kN/200Nm and 10kN/1kNm is made of aluminium alloy, the sensor K6D150 30kN/3kNm is made of high-strength stainless steel 1.4542.

Technical Drawing

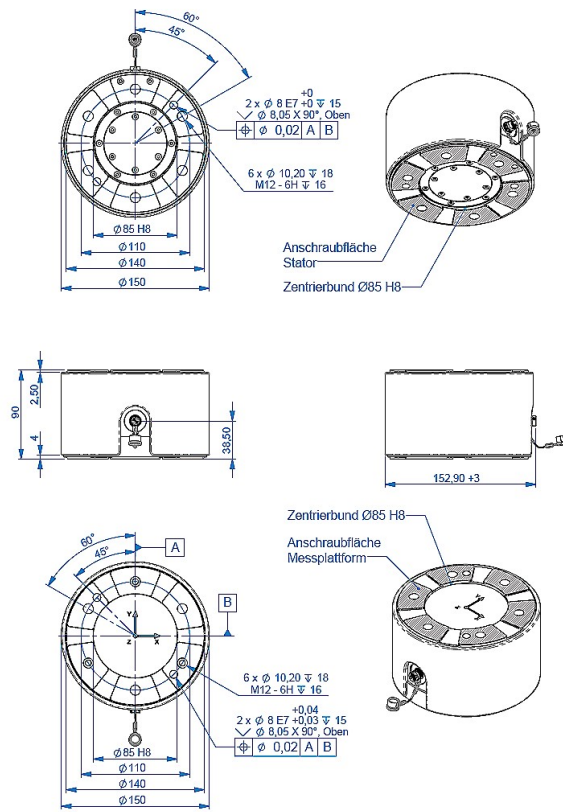

Technical Data

Basic Data		Unit
Type	6-axis force sensor	
Force direction	Tension/Compression	
Rated force Fx	2	kN
Rated force Fy	2	kN
Rated force Fz	5	kN
Force introduction	Internal thread	
Dimension 1	6xM12x1,75	
Sensor Fastening	Internal thread	
Dimension 2	6xM12x1,75	
Operating force	300	%FS
Material	aluminum-alloy	
Height	90	mm
Length or Diameter	150	mm
Rated torque Mx	200	Nm
Rated torque My	200	Nm
Rated torque Mz	200	Nm
Torque limit	300	%FS
Bending moment limit	200	%FS

Electrical Data		Unit
Input resistance	350	Ohm
Tolerance input resistance	10	Ohm
Output resistance	350	Ohm
Tolerance output resistance	10	Ohm
Insulation resistance	2	GOhm
Rated range of excitation voltage from	2.5	V
Rated range of excitation voltage to	5	V
Operating range of excitation voltage from	1	V
Operating range of excitation voltage to	5	V
Zero signal from	-0.05	mV/V
Zero signal to	0.05	mV/V
Rated output	0.8	mV/V

Eccentricity and Crosstalk		Unit
Crosstalk	1	%FS

Accuracy Data		Unit
Accuracy class	0,2	
Relative linearity error	0.1	%FS
Relative zero signal hysteresis	0.1	%FS
Temperature effect on zero signal	0.1	%FS/K
Temperature effect on characteristic value	0.01	%RD/K
Relative creep	0.1	%FS
Relative repeatability error	0.2	%FS

Environmental Data		Unit
Rated temperature range from	-10	°C
Rated temperature range to	70	°C
Operating temperature range from	-10	°C
Operating temperature range to	85	°C
Storage temperature range from	-10	°C
Storage temperature range to	85	°C
Environmental protection	IP65	

Abbreviation : RD: „Reading“; FS: „Full Scale“; The application of a calibration matrix is required for the determination of the forces F_x , F_y , F_z and moments M_x , M_y , and M_z from the 6 measurement channels, and to compensate for the crosstalk.

The calibration data are individually determined and documented for the sensor.

The measurement error is expressed individually by the specification of the extended measurement uncertainty ($k = 2$) for the forces F_x , F_y , F_z , and moments M_x , M_y , M_z .

Stiffness Matrix

29.1 kN/mm	0.0	0.0	0.0	1308 kN/rad	0.0
0.0	29.1 kN/mm	0.0	-1308 kN/rad	0.0	0.0
0.0	0.0	137.7 kN/mm	0.0	0.0	0.0
0.0	-1308 kN/mm	0.0	216.3 kNm/rad	0.0	0.0
1308 kN/mm	0.0	0.0	0.0	216.3 kNm/rad	0.0
0.0	0.0	0.0	0.0	0.0	132.9 kNm/rad

- The elements with the unit kN/mm describe the relationship between force and path.
- The elements with the unit kNm describe the relationship between torque and twist.
- The elements with the unit kN describe the relationship between torque and path (columns 1 to 3) or the relationship between force and twist (columns 4 to 6)