

6-Axis Force Sensor K6D80 500N/20Nm/MP11

Item number: 9716



The multi-component sensor K6D80 allows force and torque measurement in three mutually perpendicular axes. The multi-component sensor K6D80 distinguishes itself by a big measuring range for torques at the same time with the small outer diameter. With this multi-component sensor of the „second generation“ is used rod construction, which absorbs forces and torques directly on the pitch circle of the fastening thread. Thereby, the maximum stiffness and the biggest measuring range will be achieved for the torques. The force transmission is applied on the 1 mm raised segments. The inner diameter of segments is used for the centering. Due to segmented, ring-shaped front surface, the optimal force transmission and therefore the best possible reproducibility in the range of about 0,1 % will be obtained. The multi-component force sensor is very well suited for use in robotics, e.g.

- For collision detection
- „Teach-In“
- Presence detection and error detection
- Force or torque-controlled operation
- Load measurement in medicine, prosthetics, orthopaedic engineering or gait analysis
- Measurement in sports medicine
- Comfort / ergonomics measurements

The force and torque loadings are evaluated e.g. using a GSV-8AS measurement amplifier or an integrated electronic of type GSV-6. The sensor K6D80 2kN/100Nm is made of aluminium alloy, the sensor K6D80 5kN/250Nm is made of high-strength stainless steel 1.4542.

Technical Drawing

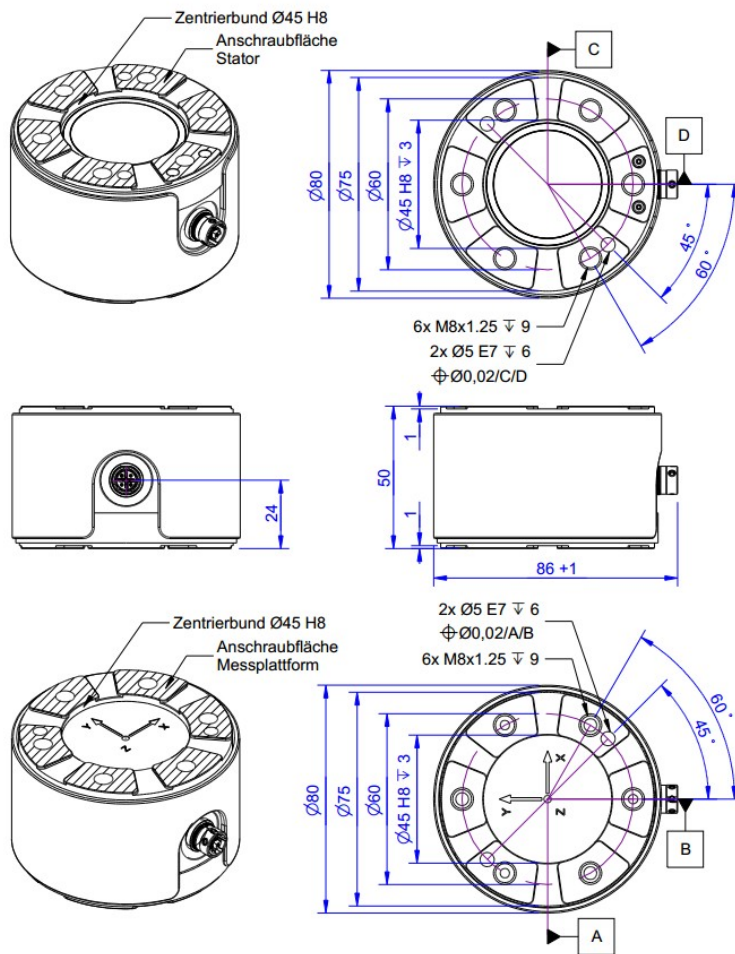

Technical Data

Basic Data		Unit
Type	6-axis force sensor	
Force direction	Tension/Compression	
Rated force Fx	500	N
Rated force Fy	500	N
Rated force Fz	1	kN
Force introduction	Internal thread	
Dimension 1	6x M8x0,1,25	
Sensor Fastening	Internal thread	
Dimension 2	6x M8x0,1,25	
Operating force	300	%FS
Rated displacement	0.05	mm
Twist	0.04	rad
Height	50	mm
Length or Diameter	80	mm
Rated torque Mx	20	Nm
Rated torque My	20	Nm
Rated torque Mz	20	Nm
Torque limit	300	% FS
Bending moment limit	300	% FS
Breaking force	600	%

Electrical Data		Unit
Input resistance	350	Ohm
Tolerance input resistance	10	Ohm
Output resistance	350	Ohm
Tolerance output resistance	10	Ohm
Insulation resistance	2	GOhm
Rated range of excitation voltage from	2.5	V
Rated range of excitation voltage to	5	V
Operating range of excitation voltage from	1	V
Operating range of excitation voltage to	5	V
Zero signal from	-0.05	mV/V
Zero signal to	0.05	mV/V
Characteristic value range from	0.5	mV/V
Characteristic value range to	0.8	mV/V

Eccentricity and Crosstalk		Unit
Crosstalk	1	%FS

Accuracy Data		Unit
Accuracy class	0,2	
Relative linearity error	0.1	%FS
Relative zero signal hysteresis	0.1	%FS
Temperature effect on zero signal	0.1	%FS/K
Temperature effect on characteristic value	0.05	%RD/K
Relative creep	0.1	%FS
Relative repeatability error	0.2	%FS

Environmental Data		Unit
Rated temperature range from	-10	°C
Rated temperature range to	70	°C
Operating temperature range from	-10	°C
Operating temperature range to	85	°C
Storage temperature range from	-10	°C
Storage temperature range to	85	°C
Environmental protection	IP65	

Abbreviation : RD: „Reading“; FS: „Full Scale“; The application of a calibration matrix is required for the determination of the forces Fx, Fy, Fz and moments Mx, My, and Mz from the 6 measurement channels, and to compensate for the crosstalk.

The calibration data are individually determined and documented for the sensor.

The measurement error is expressed individually by the specification of the extended measurement uncertainty (k = 2) for the forces Fx, Fy, Fz, and moments Mx, My, Mz.

PIN Assignment

Channel	Symbol	Designation	Color	PIN
1	+Us	positive bridge supply	white	1
	-Us	negative bridge supply	brown	2
	+Ud	positive bridge output	green	3
	-Ud	negative bridge output	yellow	4
2	+Us	positive bridge supply	gray	5
	-Us	negative bridge supply	pink	6
	+Ud	positive bridge output	blue	7
	-Ud	negative bridge output	red	8
3	+Us	positive bridge supply	black	9
	-Us	negative bridge supply	purple	10
	+Ud	positive bridge output	gray-pink	11
	-Ud	negative bridge output	red-blue	12
4	+Us	positive bridge supply	white-green	13
	-Us	negative bridge supply	brown-green	14
	+Ud	positive bridge output	white-yellow	15
	-Ud	negative bridge output	yellow-brown	16
5	+Us	positive bridge supply	white-gray	17
	-Us	negative bridge supply	gray-brown	18
	+Ud	positive bridge output	white-pink	19
	-Ud	negative bridge output	pink-brown	20
6	+Us	positive bridge supply	white-blue	21
	-Us	negative bridge supply	brown-blue	22
	+Ud	positive bridge output	white-red	23
	-Ud	negative bridge output	brown-red	24

Shield: connected with sensor housing;

Mounting

The forces is applied to an annulus ($\varnothing 75\text{-}\varnothing 45$) on the end faces of the sensor. No force is applied to the area inside the ring.

A centring hole is provided to secure the angular position.

Stiffness Matrix

14.1 kN/mm	0.0	0.0	0.0	352 kN	0.0
0,0	14.1 kN/mm	0.0	-352 kN	0.0	0.0
0.0	0.0	76.7 kN/mm	0.0	0.0	0.0
0.0	-352 kN	0.0	35.6 kNm	0.0	0.0
352 kN	0.0	0.0	0.0	35.6 kNm	0.0
0.0	0.0	0.0	0.0	0.0	19.7 kNm

- The elements with the unit kN/mm describe the relationship between force and path.
- The elements with the unit kNm describe the relationship between torque and twist.
- The elements with the unit kN describe the relationship between torque and path (columns 1 to 3) or the relationship between force and twist (columns 4 to 6)